

Operationskalpelle
Operating Knives
Bistouris pour opérations
Bisturías para operaciones

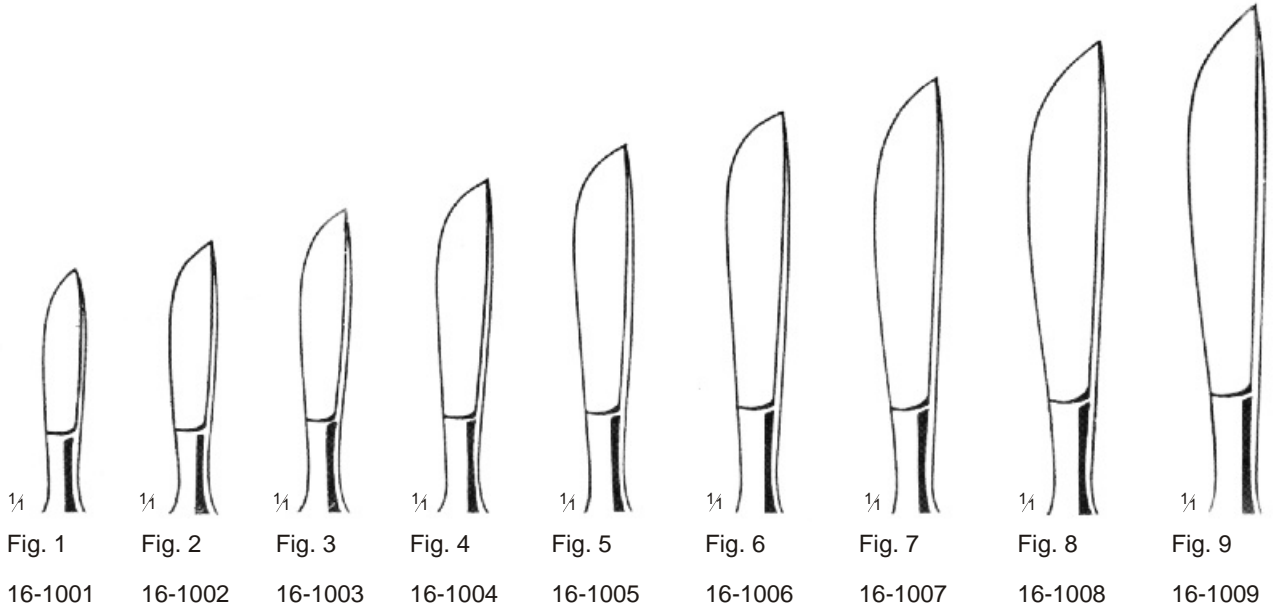
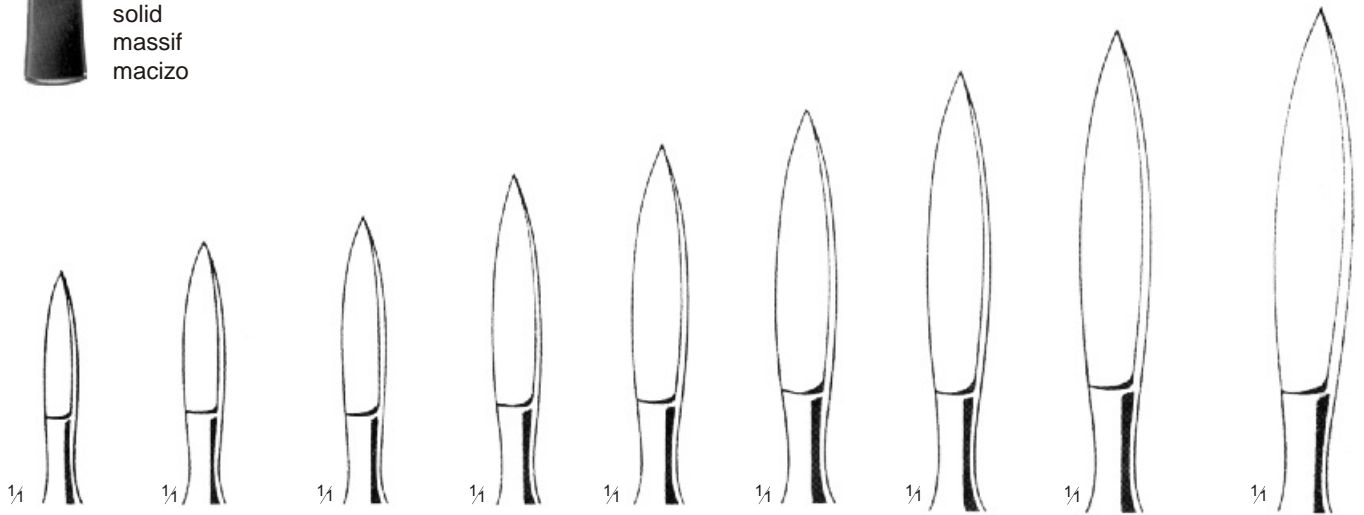

Fig. 1 16-1001 Fig. 2 16-1002 Fig. 3 16-1003 Fig. 4 16-1004 Fig. 5 16-1005 Fig. 6 16-1006 Fig. 7 16-1007 Fig. 8 16-1008 Fig. 9 16-1009

17,0 cm/6³/₄"
 massiv
 solid
 massif
 macizo



Fia. 10 16-1010 Fia. 11 16-1011 Fia. 12 16-1012 Fia. 13 16-1013 Fia. 14 16-1014 Fia. 15 16-1015 Fig. 16 16-1016 Fig. 17 16-1017 Fig. 18 16-1018

Operationskalpelle
Operating Knives
Bistouris pour opérations
Bisturías para operaciones



Fig. 26
16-1026



Fig. 27
16-1027



Fig. 32
16-1032

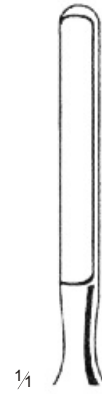

Fig. 36
16-1036



Fig. 37
16-1037



Fig. 38
16-1038



Fig. 40
16-1040



Fig. 46
16-1046



Fig. 60
16-1060



Fig. 61
16-1061



Fig. 62
16-1062



Fig. 63
16-1063



Operationskappelle
Operating Knives
Bistouris pour opérations
Bisturías para operaciones



Collin
 15,0 cm/6"
 Fig. 1-6

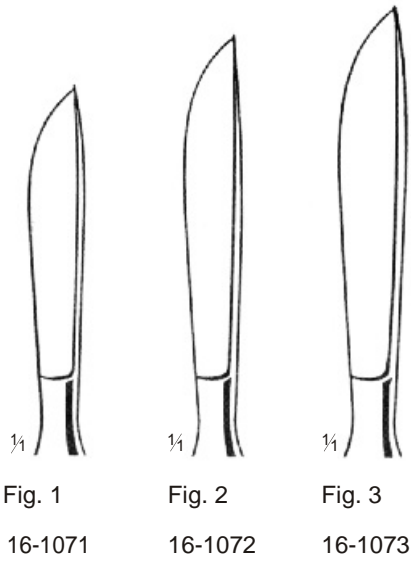

Fig. 1 16-1071
 Fig. 2 16-1072
 Fig. 3 16-1073

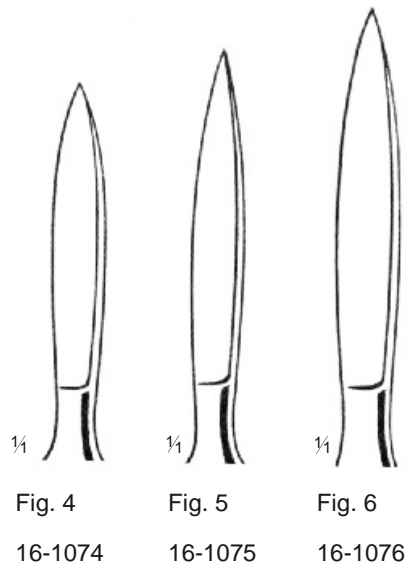

Fig. 4 16-1074
 Fig. 5 16-1075
 Fig. 6 16-1076



Dieffenbach
 17,0 cm/6¾"
 Fig. 1-9

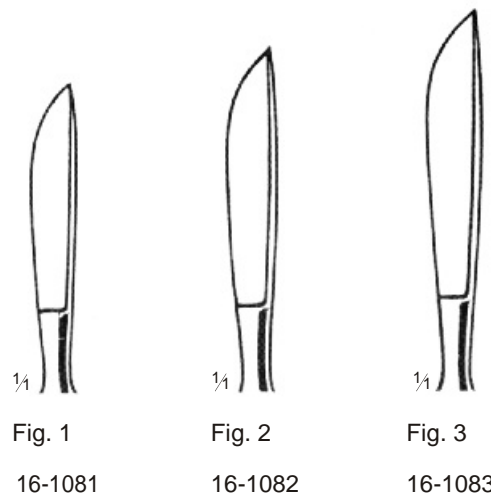

Fig. 1 16-1081
 Fig. 2 16-1082
 Fig. 3 16-1083



Fig. 4 16-1084
 Fig. 5 16-1085

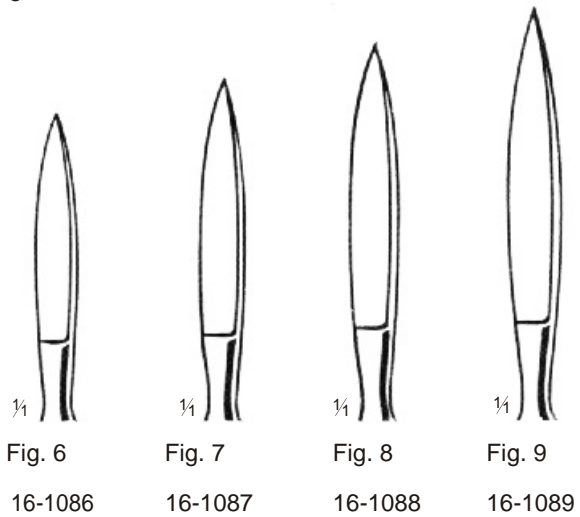
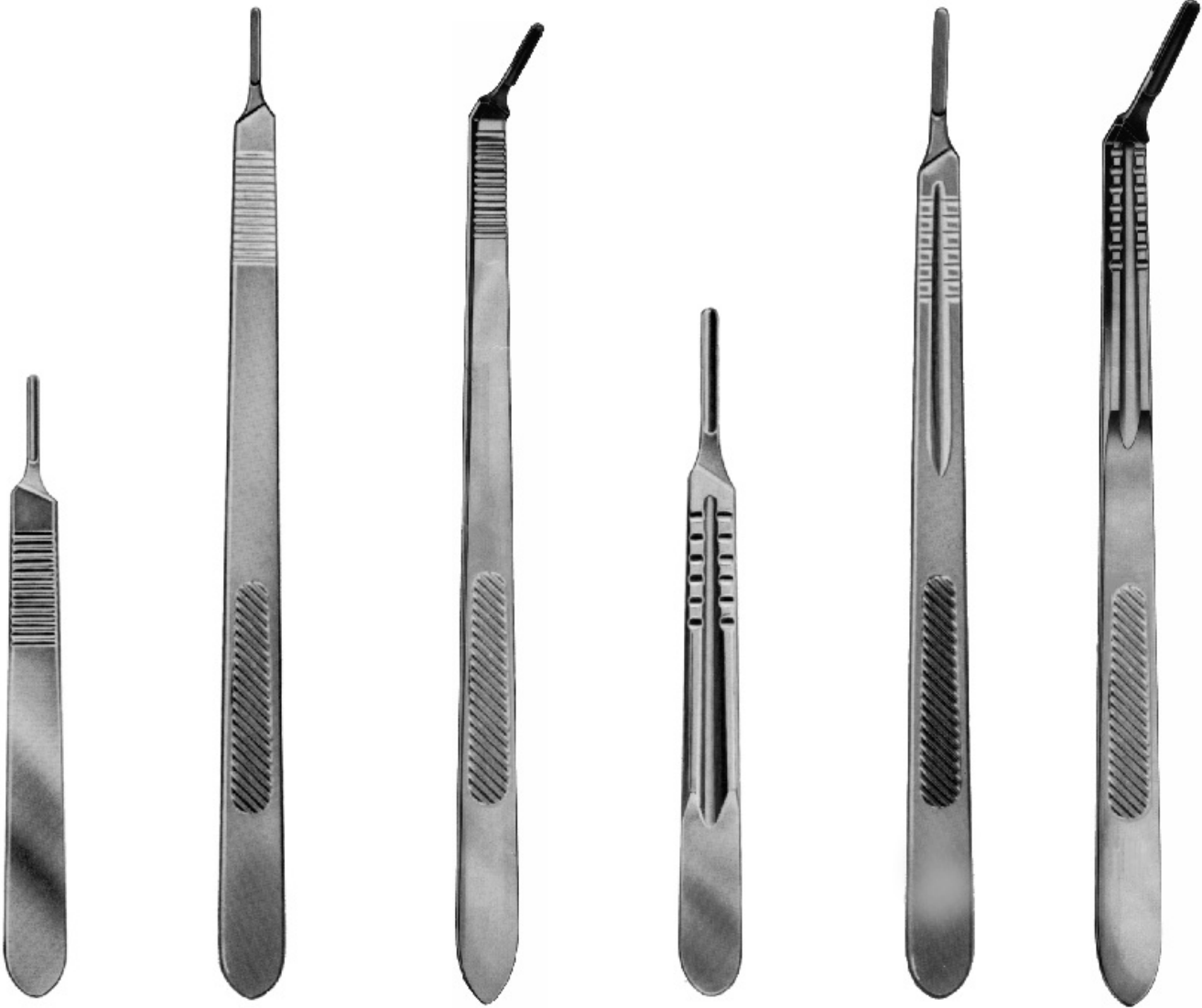

Fig. 6 16-1086
 Fig. 7 16-1087
 Fig. 8 16-1088
 Fig. 9 16-1089

Skalpelli-Griffe
 Scalpel Handles
 Manches pour bistouris
 Mangos de bisturías



Standard

16-1091
 No. 3
 massiv
 solid
 massif
 macizo

16-1092
 No. 3L
 massiv
 solid
 massif
 macizo

16-1092G
 No. 3L
 massiv, abgewinkelt
 solid, angular
 massif, coudé
 macizo, acodado

Standard

16-1095
 No. 4
 massiv
 solid
 massif
 macizo

16-1096
 No. 4L
 massiv
 solid
 massif
 macizo

16-1096G
 No. 4L
 massiv, abgewinkelt
 solid, angular
 massif, coudé
 macizo, acodado

Skalpell-Griffe
 Scalpel Handles
 Manches pour bistouris
 Mangos de bisturías



Standard
 16-1097
 No. 7
 massiv
 solid
 massif
 macizo



16-1097K
 No. 7K
 massiv
 solid
 massif
 macizo



16-1098
 No. 8
 hohl
 hollow
 creux
 hueco

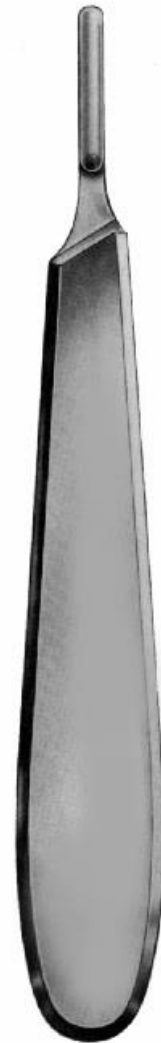

16-1099
 No. 9
 hohl
 hollow
 creux
 hueco

16

Skalpellklingen
Scalpel Blades
Lames pour bistouris
Hojas de bisturías



steril
sterile
stériles
estériles

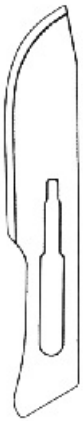

Fig. 10
Standard

16-1110

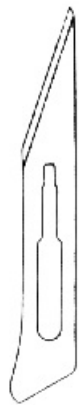

Fig. 11
Standard

16-1111



Fig. 12
Standard

16-1112



Fig. 13
Standard

16-1113

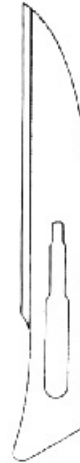

Fig. 14
Standard

16-1114

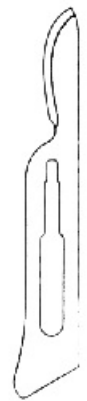

Fig. 15
Standard

16-1116

steril
sterile
stériles
estériles



Fig. 16
Standard

16-1116



Fig. 17
Standard

16-1117

Verkaufseinheit: Pack à 100 Stück
Sales unit: Package of 100 pieces
Quantité de vente: Paquet de 100 pièces
Unidad de venta: Paquet de 100 piezas



Skalpelli klingen
Scalpel Blades
Lames pour bistouris
Hojas de bisturíes



steril
sterile
stériles
estériles

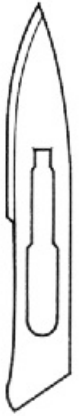

Fig. 18
Standard

16-1118



Fig. 19
Standard

16-1119



Fig. 20
Standard

16-1120



Fig. 21
Standard

16-1121



Fig. 22
Standard

16-1122



Fig. 23
Standard

16-1123



steril
sterile
stériles
estériles



Fig. 24
Standard

16-1124



Fig. 25
Standard

16-1125



Fig. 34
Standard

16-1134



Fig. 36
Standard

16-1136

Verkaufseinheit: Pack à 100 Stück
 Sales unit: Package of 100 pieces
 Quantité de vente: Paquet de 100 pièces
 Unidad de venta: Paquet de 100 piezas

Amputationsmesser
Amputating Knives
Couteaux à amputations
Cuchillos para amputación



Lappenmesser
 Flap knife
 Couteau lobaire
 Cuchilla para lóbulos

Phalangenmaesser
 Phalangeal knife
 Couteau à phalanges
 Cuchilla para falanges

Zwischenknochen-
 messer
 Interosseous knife
 Couteaux interosseux
 Cuchillas interóseos

Schnittlänge
 Length of blades
 Longueur des lames
 Largo de hojas
 cm in.

9,5	3¾					16-1187
11,0	4½					16-1188
12,0	4¾				16-1185	
13,0	5		16-1171		16-1186	
16,0	6¼	16-1172		16-1175		
17,0	6¾				16-1178	
19,0	7½	16-1173		16-1176		
20,0	8				16-1179	
22,0	8¾	16-1174		16-1177		



Resektionsmesser
Resection Knives
Couteaux à résection
Cuchillos para resección



Langenbeck
 geballt, bellied
 convexe, convexo



Langenbeck
 spitz, pointed
 pointu, agudo



Seziernmesser
 Autopsy knife
 Couteau à autopsie
 Cuchillo para autopsia

mit Schaber
 with dissector
 avec rugine
 con raspador

Schnittlänge
 Length of blades
 Longueur des lames
 Largo de hojas

cm	in.			
5,5	2¼	16-1189	16-1190	
6,5	2½			16-1191

Organmesser
Post Mortem Knives
Couteaux à autopsie
Cuchillos para órganos

Hirnmesser
Brain Knives
Couteaux à cerveau
Cuchillos para cerebro



Organmesser
 Post mortem knife
 Couteau à autopsie
 Cuchillo para órganos

Hirnmesser
 Brain knife
 Couteau à cerveau
 Cuchillo para cerebro

Walb

Virchow

Schnittlänge
 Length of blades
 Longueur des lames
 Largo de hojas

16-1194-11	11,0 cm/4½"
16-1194-14	14,0 cm/5½"
16-1194-17	17,0 cm/6¾"

16-1195-16	16,0 cm/6¼"
16-1195-20	20,0 cm/8"
16-1195-24	24,0 cm/9½"



Seziermesser
Autopsy Knives
Couteaux à autopsie
Cuchillos para autopsia

Schnittlänge
 Length of blades
 Longueur des lames
 Largo de hojas

9,0 cm/3½"

9,0 cm/3½"

12,0 cm/4¾"

20,0 cm/8"



Virchow

Virchow

16-1198
 Holzgriff
 Wooden handle
 Manche en bois
 Mango de madera

16-1199
 Metaalgriff
 Metal handle
 Manche en métal
 Mango de métal

16-1196
 Metallgriff
 Metal handle
 Manche en métal
 Mango de métal

16-1197
 Holzgriff
 Wooden handle
 Manche en bois
 Mango de madera

16

**Rektum Instrumente
Rectal Instruments
Instruments Rectaux
Instrumentos Rectales**



Hämorrhoidal-Ligatoren
Haemorrhoidal Ligators
Ligateurs hémorroïdales
Ligadores hemorroidales



17-1201-08 Ø 8 mm

17-1201-10 Ø 10 mm

21,0 cm/8½"

mit Ladekegel und Saugunterbrechung

with charging cone and suction interrupter

avec cône de charge y interruption d'aspiration

con cono-cargador y interruptor de aspiración

17-1202-08 Ø 8 mm

17-1202-10 Ø 10 mm

Ladekegel, allein

Charging cone, only

Cône de charge, seul

Cono-cargador, suelto

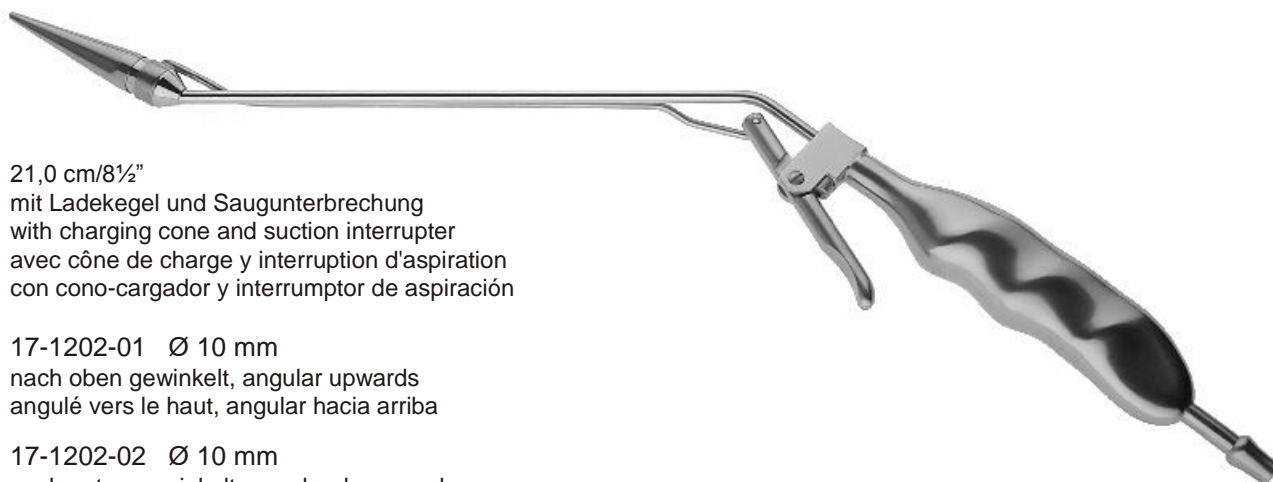

21,0 cm/8½"

mit Ladekegel und Saugunterbrechung

with charging cone and suction interrupter

avec cône de charge y interruption d'aspiration

con cono-cargador y interruptor de aspiración

17-1202-01 Ø 10 mm

nach oben gewinkelt, angular upwards

angulé vers le haut, angular hacia arriba

17-1202-02 Ø 10 mm

nach unten gewinkelt, angular downwards

angulé vers le bas, angular hacia abajo

17-1202-10

Ladekegel 10 mm

Charging cone 10 mm

Cône de charge 10 mm

Cono-cargador 10 mm

17-1203-05

Ligatur-Gummiringe, Packung à 100 Stück

Ligatur rubber rings in package of 100 pieces

Bagues de caoutchouc pour ligatures, paquet de 100 pièces

Arandelas de goma para ligadura en paquete de 100

unidades

Auf Anfrage auch mit Kaltlichtanschluß lieferbar. On request, also available with coldlight connection.

A demande aussi livrable avec connexion de lumière froide. A demanda se puede también suministrar con conexión de luz fría.

Hämorrhoidal-Ligatoren
Haemorrhoidal Ligators
Ligateurs hémorroïdales
Ligadores hemorroidales

Hämorrhoidal-Faßzangen
Hämorrhoidal Forceps
Pinces pour saisir les hémorroïdes
Pinzas hemorroidales



17-1203-01
 mit Ladekegel 12 mm, leicht zerlegbar
 with charging cone 12 mm, easily dismantable
 avec cône de charge 12 mm, facilement
 démontable
 con cono-cargador 12 mm, facilmente
 desmontable

17-1203-12
 Ladekegel 12 mm
 Charging cone 12 mm
 Cône de charge 12 mm
 Cono-cargador 12 mm

17-1203-05
 Ligatur-Gummiringe, Packung à 100 Stück
 Ligatur rubber rings in package of 100 pieces
 Bagues de caoutchouc pour ligatures,
 paquet de 100 pièces
 Arandelas de goma para ligadura en paquete
 de 100 unidades

Hämorrhoidal-Faßzangen, Hämorrhoidal Forceps, Pinces pour saisir les hémorroïdes, Pinzas hemorroidales



McGivney
17-1204-01
 19,0 cm/7½"



McGivney
17-1204-02
 19,0 cm/7½"



Laufe
17-1205-20
 20,5 cm/8¼"



Anuskope
Anusopes
Anusopes
Anuscopios

Proktoskope
Proctoscopes
Proctoscopes
Proctoscopios

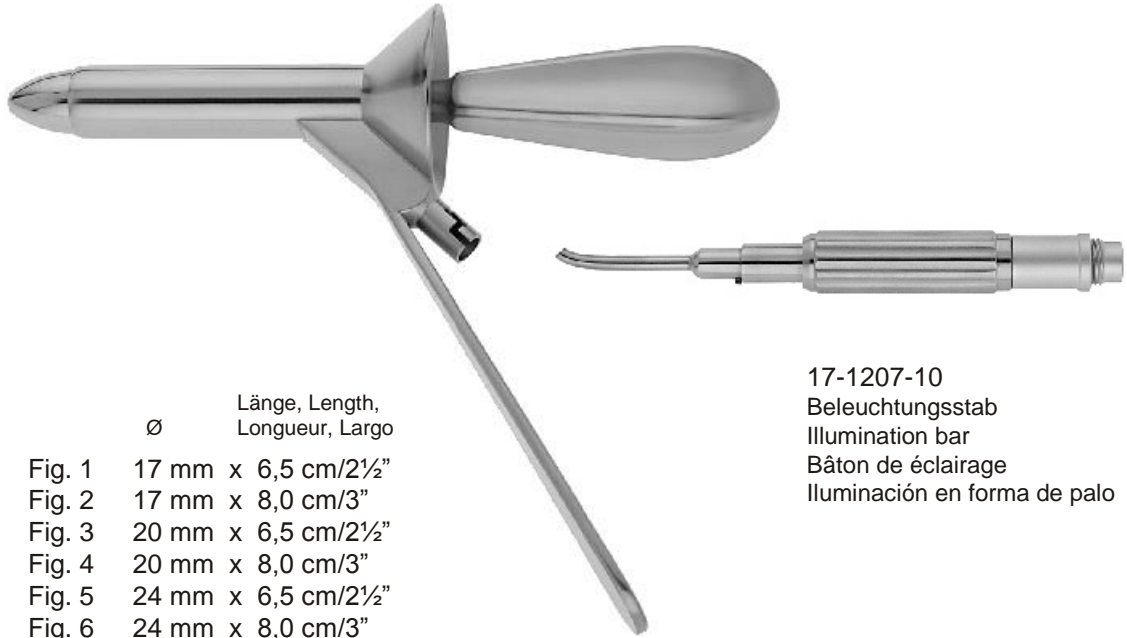

Morgan

		∅	Länge, Length, Longueur, Largo
17-1207-01	Fig. 1	17 mm	6,5 cm/2½"
17-1207-02	Fig. 2	17 mm	8,0 cm/3"
17-1207-03	Fig. 3	20 mm	6,5 cm/2½"
17-1207-04	Fig. 4	20 mm	8,0 cm/3"
17-1207-05	Fig. 5	24 mm	6,5 cm/2½"
17-1207-06	Fig. 6	24 mm	8,0 cm/3"

17-1207-10
Beleuchtungsstab
Illumination bar
Bâton de éclairage
Iluminación en forma de palo



Anuskope
Anusopes
Anusopes
Anuscopios

Hirschmann

		∅	Länge, Length, Longueur, Largo
17-1208-01	Fig. 1	16 mm	6,5 cm/2½"
17-1208-02	Fig. 2	19 mm	6,5 cm/2½"
17-1208-03	Fig. 3	22 mm	6,5 cm/2½"

Hirschmann

		∅	Länge, Length, Longueur, Largo
17-1208-04	Fig. 4	22 mm	13 cm/5"

17

Anuskope **Proktoskope**
Anusopes **Proctoscopes**
Anusopes **Proctoscopes**
Anuscopios **Proctoscopios**



Chelsea Eaton

		∅	Länge, Length, Longueur, Largo
17-1209-22	Fig. 1	22 mm	x 6,5 cm/2½"
17-1209-30	Fig. 2	30 mm	x 6,5 cm/2½"



Anoskop
 Anuscope
 Anuscope
 Anuscopio

Bensaude

		∅	Länge, Length, Longueur, Largo
17-1210-19	Fig. 1	19 mm	x 7,0 cm/2¾"
17-1210-22	Fig. 2	22 mm	x 7,0 cm/2¾"



Anuskope
Anusopes
Anusopes
Anuscopios

Proktoskope
Proctoscopes
Proctoscopes
Proctoscopios

Sphinkterskope
Sphincteroscopes
Sphinctérosopes
Esfincteroscopios



Sphinkterskope
Sphincteroscopes
Sphinctérosopes
Esfincteroscopios

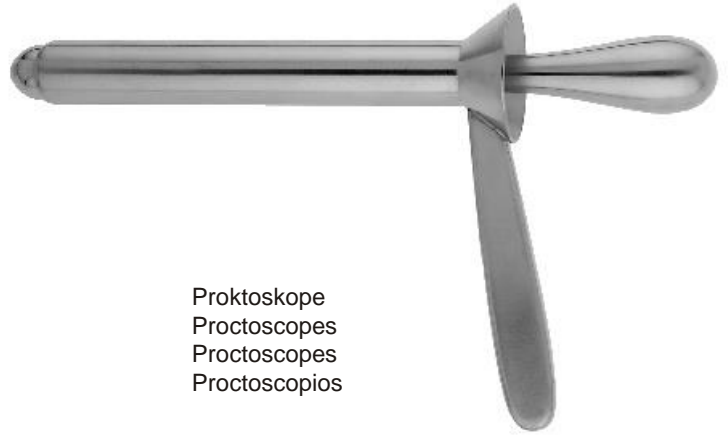

Proktoskope
Proctoscopes
Proctoscopes
Proctoscopios

Kelly		Ø	Länge, Length, Longueur, Largo
17-1211-21	Fig. 1	21 mm	x 5,0 cm/2"
17-1211-25	Fig. 2	25 mm	x 5,0 cm/2"

Kelly		Ø	Länge, Length, Longueur, Largo
17-1212-01	Fig. 1	22 mm	x 5,0 cm/2"
17-1212-02	Fig. 2	22 mm	x 10,0 cm/4"
17-1212-03	Fig. 3	22 mm	x 14,5 cm/6"
17-1212-04	Fig. 4	22 mm	x 20,0 cm/8"

17



Anuskope
Anusopes
Anusopes
Anuscopios

Ives-Fansler		Ø	Länge, Length, Longueur, Largo
17-1213-22		22 mm	x 9,5 cm/4"

mit Kaltlichtanschluß
with cold lightconnection
avec connexion de lumière froide
con conexión de luz fría

Ives-Fansler		Ø	Länge, Length, Longueur, Largo
17-1214-22		22 mm	x 9,5 cm/4"

Mastdarm-Spekula
Rectal Specula
Spéculums rectaux
Espéculos rectales

Anal spreizer
Anal Retractors
Ecarteurs rectaux
Separadores rectales



Anal spreizer
 17-1215-01
 18,0 cm/7"
 15/30 x 70 mm

17-1215-10
 Kaltlichtaufsatz
 Cold light attachment
 Élément de lumière froide
 Empalme de luz fría



Anal spreizer
 18,0 cm/7"
 15/30 x 70 mm

17-1215-02
 mit Kaltlichtaufsatz
 with cold light attachment
 avec élément de lumière
 froide
 con empalme de luz fría



70 x 22 mm

Mastdarm-Spekula
 Rectal Specula
 Spéculums rectaux
 Espéculos rectales

Barr

17-1216-17
 17,0 cm/6¾"

Anal spreizer
 Anal Retractors
 Ecarteurs rectaux
 Separadores rectales

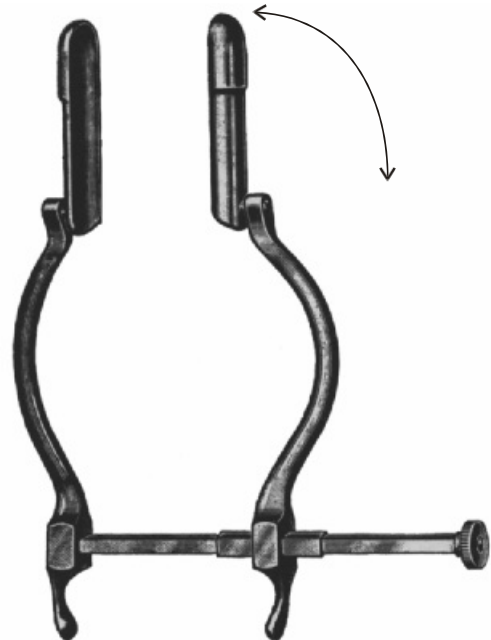

Smith-Buie

17-1218-15
 15,0 cm/6"



Analpreizer
Anal Retractors
Ecarteurs rectaux
Separadores rectales



Alan Parks

17-1220-00
 13,5 cm/13¼"

bestehend aus:
 consisting of:
 composé de:
 compuesto de:

- 17-1220-01
- 17-1220-02
- 17-1220-03 2x
- 17-1220-04 2x

17-1220-01
 Sperrer, allein
 Spreader, only
 Ecarteur, seul
 Separador, suelto

17-1220-02
 Mittelblatt, allein
 Center blade, only
 Valve centrale, seule
 Valva central, suelta
 95 x 24 mm

17-1220-03
 Blatt, allein
 Blade, only
 Valve, seule
 Valva, suelta
 75 x 24 mm

17-1220-04
 Blatt, allein
 Blade, only
 Valve, seule
 Valva, suelta
 95 x 24 mm

Mastdarm-Spekula
Rectal Specula
Spéculums rectaux
Espéculos rectales



Czerny
17-1223-22
22,0 cm/8³/₄"



Sims
(Bodenhammer)
17-1224-01
15,0 cm/6"

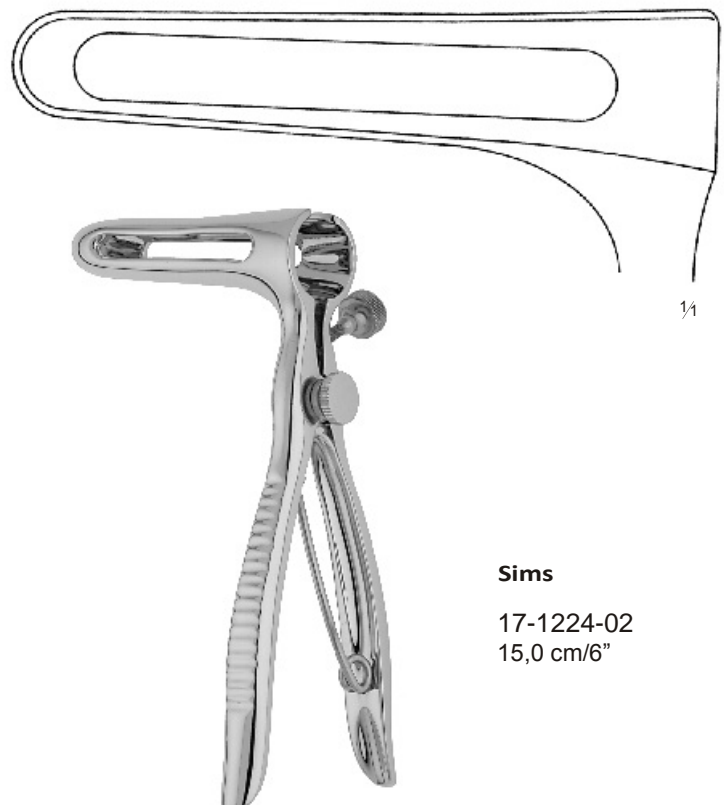

Sims
17-1224-02
15,0 cm/6"



Mastdarm-Spekula
Rectal Specula
Spéculums rectaux
Espéculos rectales

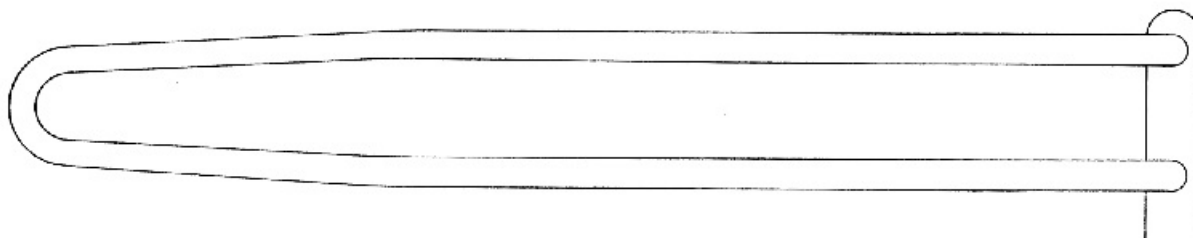

23 x 150 mm

17-1225-01

1/4

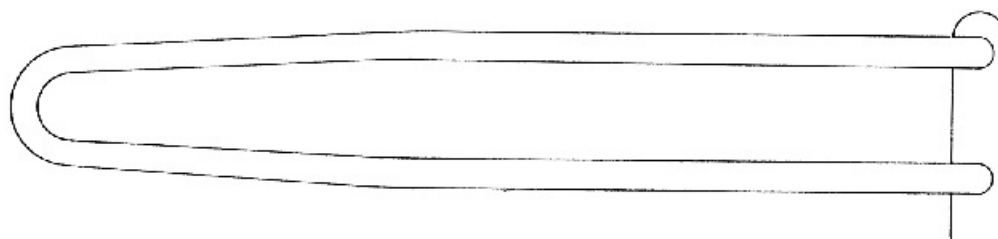

23 x 125 mm

17-1225-02

1/4

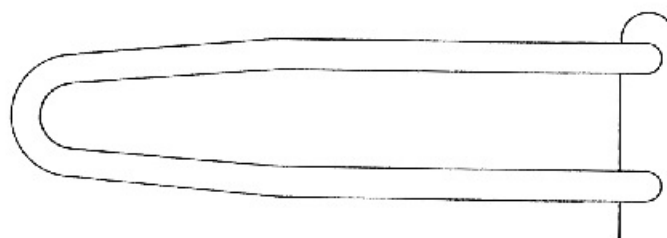

23 x 80 mm

17-1225-03

1/4

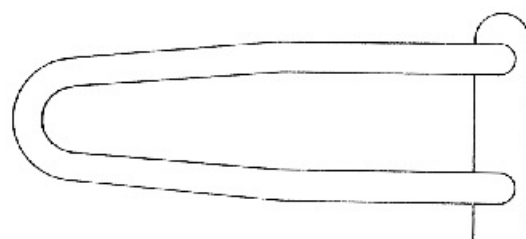

20 x 60 mm

17-1225-04

1/4



Sims

Gesamtlänge
 Total length,
 Longueur totale
 Largo total

17-1225-01	24,0 cm/9½"
17-1225-02	24,0 cm/9½"
17-1225-03	24,0 cm/9½"
17-1225-04	17,0 cm/6¾"

17

Auf Anfrage auch mit Kaltlichtanschluß lieferbar. On request, also available with coldlight connection.
 A demande aussi livrable avec connexion de lumière froide. A demanda se puede también suministrar con conexión de luz fría.

Mastdarm-Biopsiezangen
Rectal Biopsy Specimen Forceps
Pinces à biopsie rectale
Pinzas para biopsia rectal

Schaftlängen · Length of shaft · Longueur de tige · Largo del asta

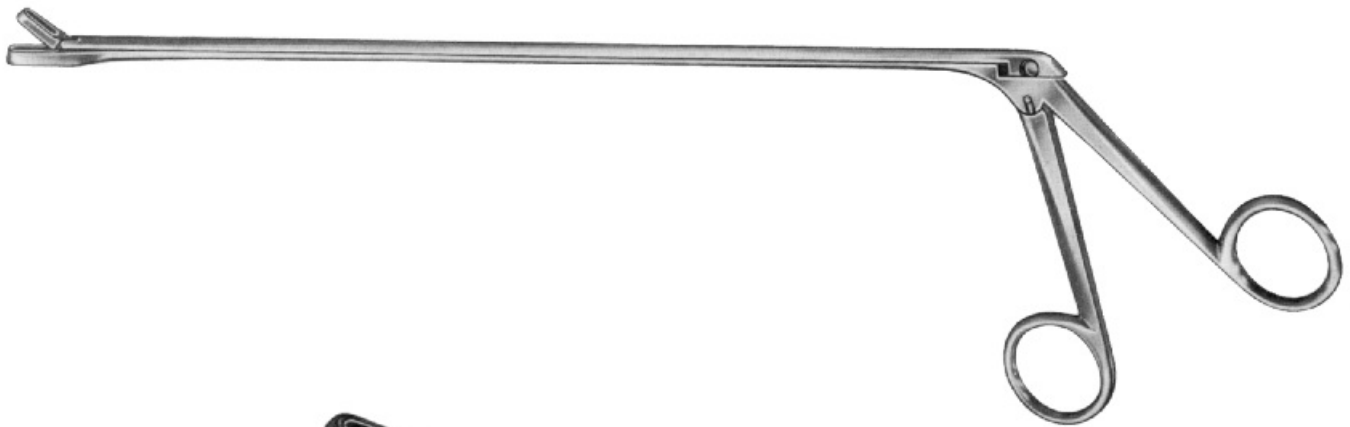
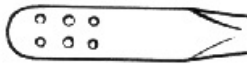
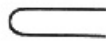

Fig. 1



3,5 x 14 mm

Yeoman

17-1230-28	28 cm/11"
17-1230-35	35 cm/13¾"
17-1230-42	42 cm/16½"

Fig. 2

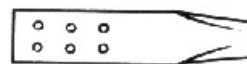
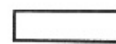

3,5 x 14 mm

Yeoman

17-1231-28	28 cm/11"
17-1231-35	35 cm/13¾"
17-1231-42	42 cm/16½"

Mastdarm-Biopsiezangen
Rectal Biopsy Specimen Forceps
Pinces à biopsie rectale
Pinzas para biopsia rectal

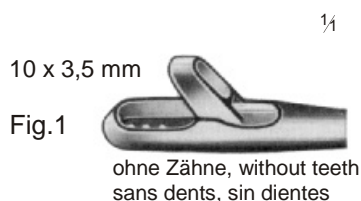
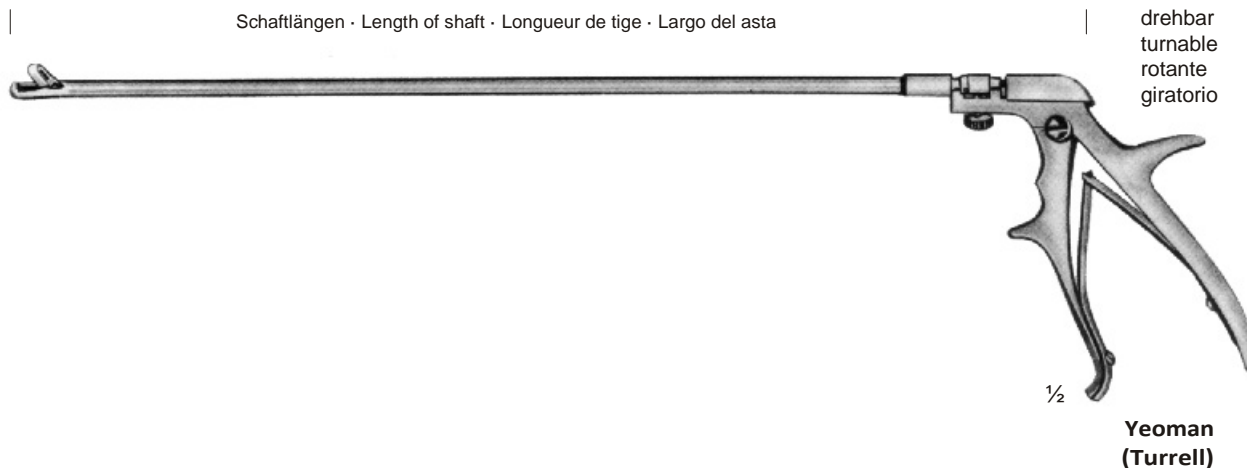

Zange komplett mit Griff Forceps complete with handle Pince complète avec manche Pinza completa con mango	Schaftlänge Length of shaft Longueur de tige Largo del asta	Aufsatz allein Attachment only Embout seul Punta suelta
17-1233-33	33 cm / 13"	17-1233-01
17-1233-40	40 cm / 16"	17-1233-02
17-1234-33	33 cm / 13"	17-1234-01
17-1234-40	40 cm / 16"	17-1234-02
17-1235-33	33 cm / 13"	17-1235-01
17-1235-40	40 cm / 16"	17-1235-02
17-1236-33	33 cm / 13"	17-1236-01
17-1236-40	40 cm / 16"	17-1236-02

Auswechselbare Griffe für Mastdarm-Biopsiezangen
Interchangeable handles for Rectal Biopsy Specimen Forceps
Manches interchangeables pour pinces à biopsie rectale
Mangos intercambiables para pinzas para biopsia rectal



Universal
17-1240-01



Yeoman
17-1240-02
Ringgriff
Ring Handle
Manche d'anneaux
Mango de anillo



Walton
17-1240-03



Saugrohre
Suction Tubes
Tubes d'aspiration
Canulas de aspiración

Sonden
Directors
Sondes rectaux
Sondas rectales

Rektal-Schnürer
Rectal snares
Serre-noeuds rectaux
Cierre-nudos rectales

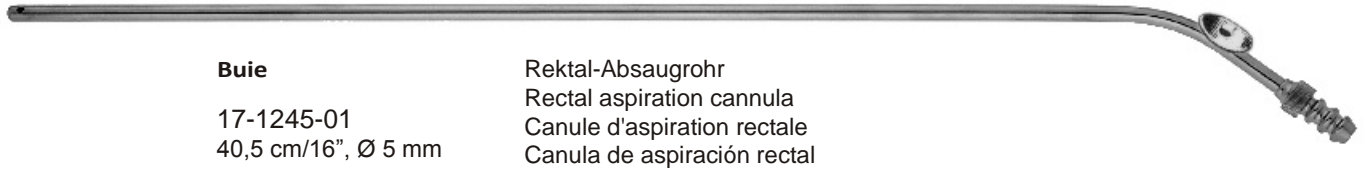

Buie
17-1245-01
40,5 cm/16", Ø 5 mm
Rektal-Absaugrohr
Rectal aspiration cannula
Canule d'aspiration rectale
Canula de aspiración rectal

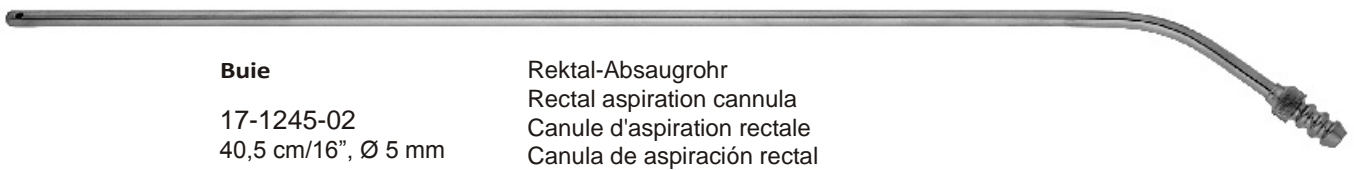

Buie
17-1245-02
40,5 cm/16", Ø 5 mm
Rektal-Absaugrohr
Rectal aspiration cannula
Canule d'aspiration rectale
Canula de aspiración rectal



Larry
17-1246-15
15,0 cm/6"
biegsam, malleable
malléable, maleable
Rektal-Sonde
Rectal director
Sonde rectale
Sonda rectal

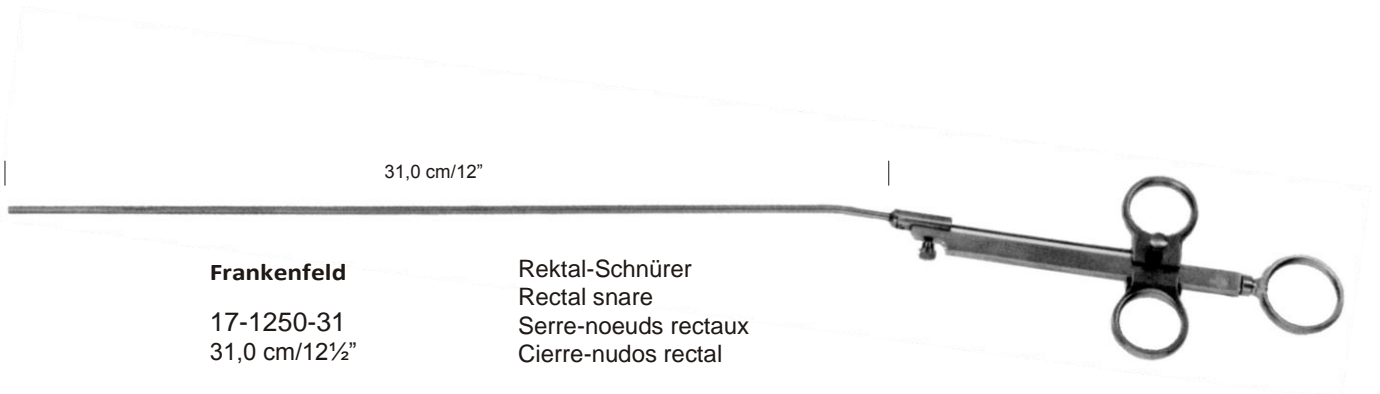

Frankenfeld
17-1250-31
31,0 cm/12½"
Rektal-Schnürer
Rectal snare
Serre-noeuds rectaux
Cierre-nudos rectal



17-1250-03 0,3 mmØ
Pack à 12 Stück
Pack of 12 pieces
Paquet à 12 pièces
Paquete con 12 piezas
Stahldraht für Rektalschnürer
Steel wire for rectal snares
Anses en fil d'acier pour serre- noeuds rectaux
Alambre de acero para cierre-nudos rectales

Watte- und Tupferträger
 Cotton Applicators
 Porte-cotons
 Porta-algodones

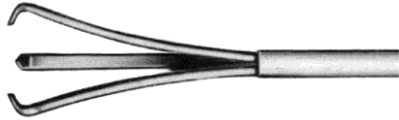

Frankfeldt
 17-1251-36 36,0 cm/14½"
 Dreiteiliges Maul
 Jaw of three pieces
 Mors à trois pièces
 Boca de tres piezas



17-1252-28 28,0 cm/11¼"
 17-1252-38 38,0 cm/15¼"
 Zweiteiliges Maul
 Jaw of two pieces
 Mors à deux pièces
 Boca de dos piezas



Eder
 17-1253-28 28,0 cm/11¼"
 17-1253-38 38,0 cm/15¼"
 Dreiteiliges Maul
 Jaw of three pieces
 Mors à trois pièces
 Boca de tres piezas



Kaltlichtquelle und Zubehör
Cold light source and accessories
Source de lumière froide et accessoires
Fuente de luz fría y accesorios



17-1260-00
 Kaltlichtquelle
 Coldlight source
 Source de lumière froide
 Fuente de luz fría
 150 Watt/230 Volt



Kaltlichtkabel
 Fibre optic cable
 Câble de lumière froide
 Cable de luz fría

Ø	Länge, Length Longueur, Largo	
	180 cm/72"	230 cm/92"
3,5 mm	17-1261-35	17-1262-35
4,5 mm	17-1261-45	17-1262-45
6,0 mm	17-1261-60	17-1262-60

Adapter für
 Adapter for
 Adapter pour
 Adaptador para

Projektorseite, projector side, côte du projecteur, lado del proyector	
Volpi, Schöolly, Loptec, RFQ	17-1265-01
Storz	17-1265-02
Henke Sass Wolf, Wolf, Richards	17-1265-03
Heine, ACM	17-1265-04
Winter, Ibe	17-1265-05
Olympus	17-1265-06
Schott, Zeiss	17-1265-07
Dyonics	17-1265-08

Instrumentenseite, instrument side, côte de l'instrument, lado del instrumento	
Storz, Winter, Ibe	17-1266-01
Henke Sass Wolf, Wolf, Richards	17-1266-02
ACM, Heine	17-1266-03
Stryker	17-1266-04
Schott, Zeiss	17-1266-05

**Neurochirurgie und Laminektomie
Neurosurgery and Laminectomy
Neurochirurgie et Laminectomie
Neurocirugía y Laminectomía**

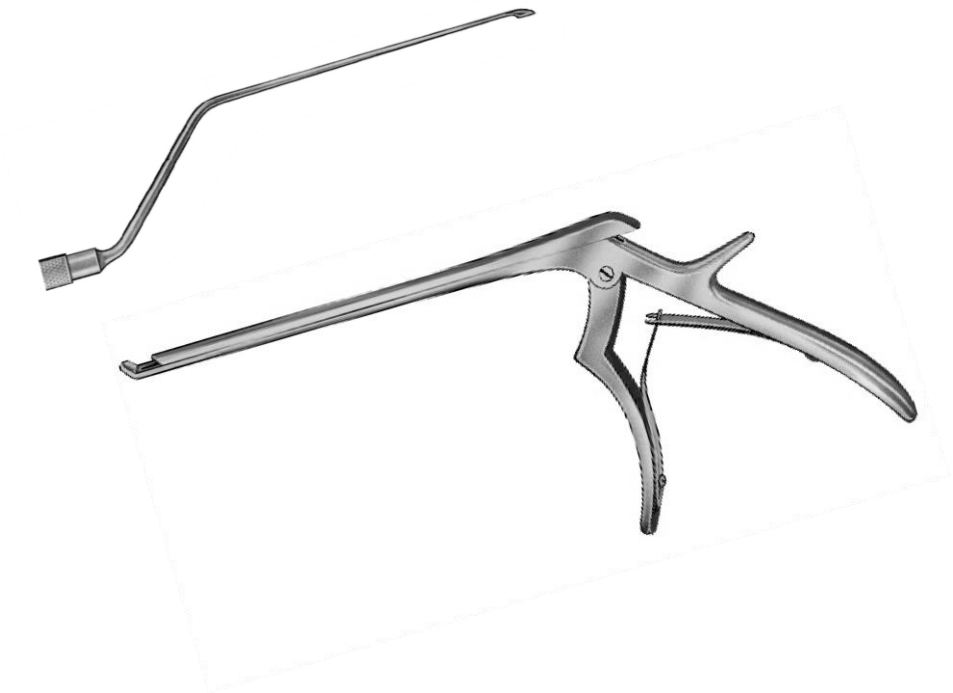

Instrumente zur Schädelöffnung
Instruments for Cranial Opening
Instrumentos pour l'ouverture du crâne
Instrumentos para abertura craneana

Drahtsäge
 Wire Saw
 Scie en fil
 Sierra de hilo

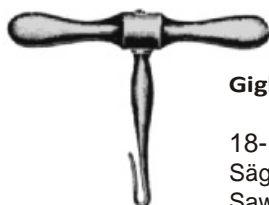
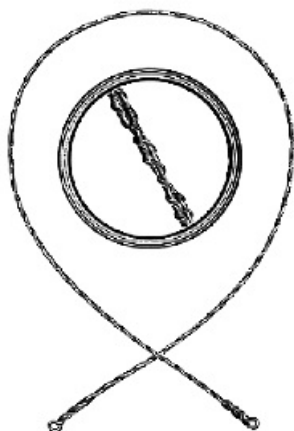

Gigli

18-1323-00
 Sägegriff
 Saw handle
 Manche pour scies
 Mango para sierras



Olivecrona

2-fach, two-fold, à deux pièces,
 de dos piezas

1,2 mmØ

- | | | |
|------------|--------|-----------|
| 18-1320-30 | Fig. 1 | 30 cm/12" |
| 18-1320-40 | Fig. 2 | 40 cm/16" |
| 18-1320-50 | Fig. 3 | 50 cm/20" |
| 18-1320-60 | Fig. 4 | 60 cm/24" |
| 18-1320-70 | Fig. 5 | 70 cm/28" |

Gigli

3-fach, three-fold, à trois pièces,
 de tres piezas

1,4 mmØ

- | | | |
|----------------|--------|-----------|
| 18-1321-30 | Fig. 1 | 30 cm/12" |
| 18-1321-40 | Fig. 2 | 40 cm/16" |
| 18-1321-50 | Fig. 3 | 50 cm/20" |
| 1,8 mmØ | | |
| 18-1322-50 | Fig. 1 | 50 cm/20" |

Martel

Einführungsinstrument für Drahtsägen
 Conductor for wire saws
 Conducteur pour scies en fil
 Conductores para sierras de hilo

- | | |
|------------|--------------|
| 18-1324-30 | 30,0 cm/12" |
| 18-1324-33 | 33,0 cm/13¼" |



Schädelzangen
 Skull-Cutting Forceps
 Pinces pour le crâne
 Pinzas para el cráneo

Dahlgren

18-1328-20
 20,0 cm/8"



De Vilbiss

18-1329-21
 21,0 cm/8¼"

Schädelhalter
Cervical Traction Tongs
Pinces de traction crânienne
Pinzas de tracción craneal



18-1340-00
 Schädelhalter für die Extension des Halswirbels, Dorne verstellbar,
 Vorbohren nicht erforderlich

Cervical Traction Tong, for extension of the neck vertebrae,
 pins adjustable hence no initial drilling

Pince de traction crânienne, pour l'extension des vertèbres
 cervicales,
 madrins réglables supprimant la perforation initiale

Pinza de tracción craneal para la extensión de las vertebrae de
 cuello,
 puntas ajustables suprimiendo perforaciones iniciales

18-1340-01
 Ersatzdorn, Spare pin only, Pointe de rechange seule,
 Punta de repuesto suelta



Crutchfield
Fig. 1
18-1341-01
 Schädelhalter
 Cervical Traction Tong
 Pince de traction crânienne
 Pinza de tracción craneal

Ø 3,5 mm



Ø 5,0 mm



18-1341-04
 3,5 mm

18-1341-05
 5,0 mm

Vorbohrer für Crutchfield Schädelhalter
 Drill Point for Crutchfield Cervical
 Traction Tongs
 Alésoir pour pinces de traction
 crânienne de Crutchfield
 Perforador inicial para pinzas de
 tracción craneal de Crutchfield



Crutchfield
Fig. 2
18-1341-02
 Schädelhalter
 Cervical Traction Tong
 Pince de traction crânienne
 Pinza de tracción craneal



Wirbelkörperspreizer
Lamina Spreaders
Ecarteurs pour corps vertébraux
Separadores para cuerpos vertebrales



Cloward
 18-1345-16
 16,0 cm/6½"

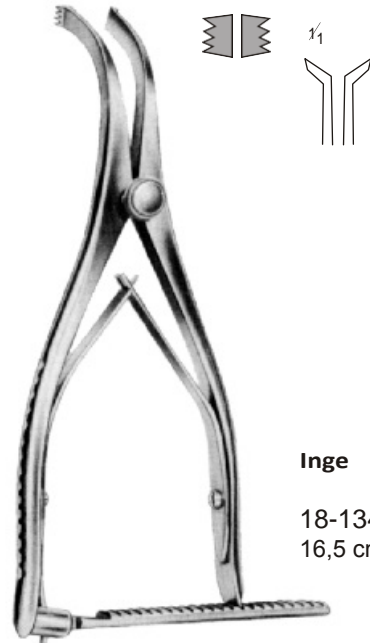

Inge
 18-1345-17
 16,5 cm/6½"

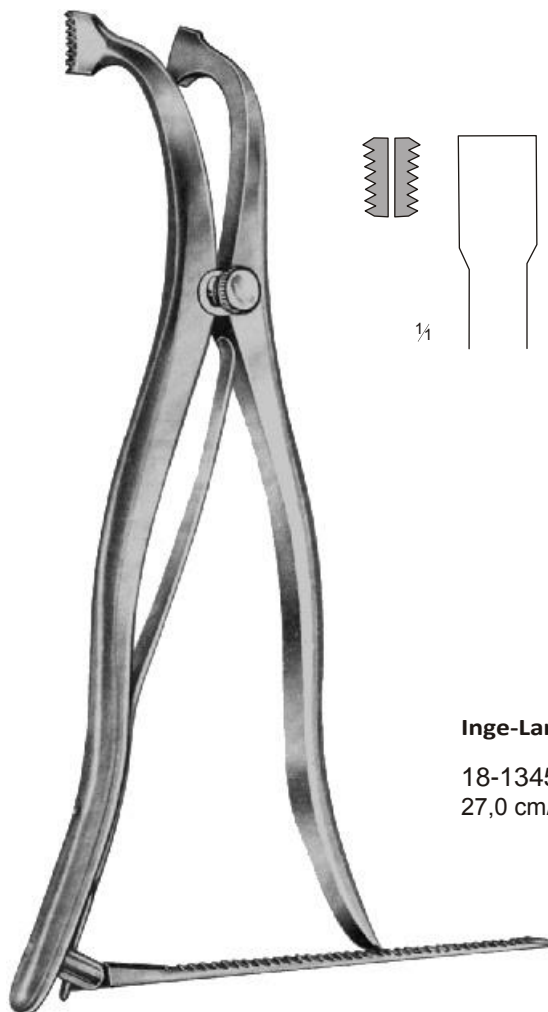

Inge-Lamina
 18-1345-27
 27,0 cm/10¾"

188
1

Klammern **Klammer-Anlegezangen**
Clips **Clip Applying Forceps**
Agrafes **Pinces pour appliquer des agrafes**
Grapas **Pinzas para poner grapas**

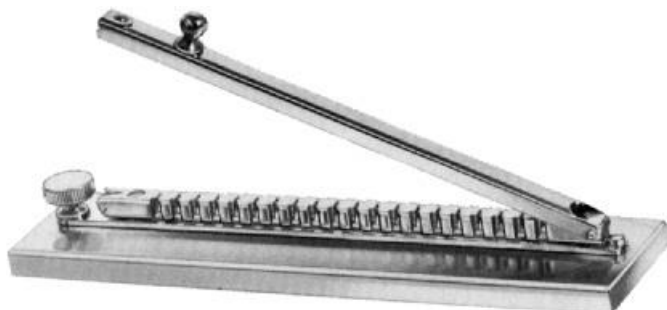

Mc Kenzie

18-1350-01
 Klammernblock mit 1 Klammerbügel
 Brain Clip Carrier, with 1 clip holding rack
 Support porte-agrafe, avec 1 rangée d'agrafes
 Porta-grapas, con 1 riel para grapas
 148 x 40 x 6 mm / 5¾ x 1½ x ¼"



18-1351-00
 100 Stück Silberklammern in Plastikbehälter
 100 pieces Silver Brain Clips in plastic case
 100 pièces agrafes en argent, dans une boîte de plastique
 100 piezas grapas de plata en tubo de plástico

¼

18-1350-02
 Klammernblock mit 2 Klammerbügel und Schiebedeckeln
 Brain Clip Carrier, with 2 clip holding rack and sliding covers
 Support porte-agrafe, avec 2 rangée d'agrafes et couvercle à glissière
 Porta-grapas, con 2 rieles para grapas y tapas corredizas
 190 x 48 x 13 mm / 7½ x 2 x ½"

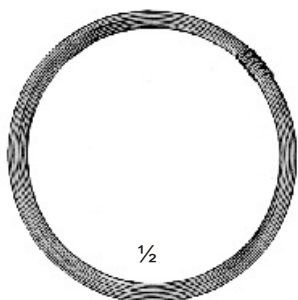

McKenzie

18-1352-00
 Silberdraht in Ringen zu 2,5 Gramm
 Silver Wire in coils of 2,5 g
 Fil d'argent, par rouleaux de 2,5 g
 Hilo de plata en rollos de 2,5 g

½



Raney

18-1354-00
 16,0 cm/6½"
 Anlege- und Abnehmezange für Kopfhaut-klammern
 Applying and Removing Forceps for Scalp Hemostasis Clips
 Pince pour appliquer et enlever les clips hémostatiques pour le cuir chevelu
 Pinza para aplicar y quitar clips hemostáticas para el cuero cabelludo



Raney

18-1353-00
 Kopfhautklammer
 Scalp Hemostasis Clip
 Clip hémostatique pour le cuir chevelu
 Clip hemostática para el cuero cabelludo

½



Klammer-Anlegezangen
Clip Applying Forceps
Pinces pour appliquer des agrafes
Pinzas para poner grapas

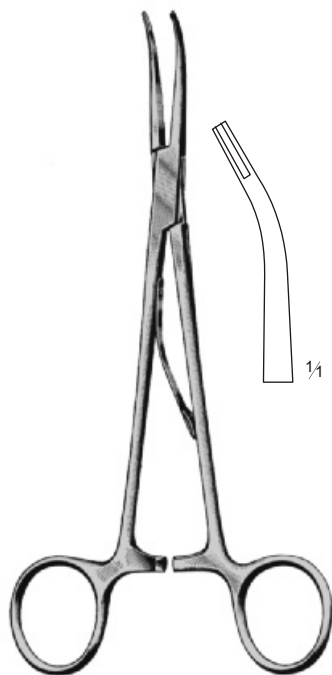

Klammer-Anlegezangen,
gebogen
Clip Applying Forceps,
curved
Pinces pour appliquer des
agrafes, courbes
Pinzas para poner grapas,
curvas

McKenzie

18-1360-15 15,0 cm/6"
 18-1360-19 19,0 cm/7½"

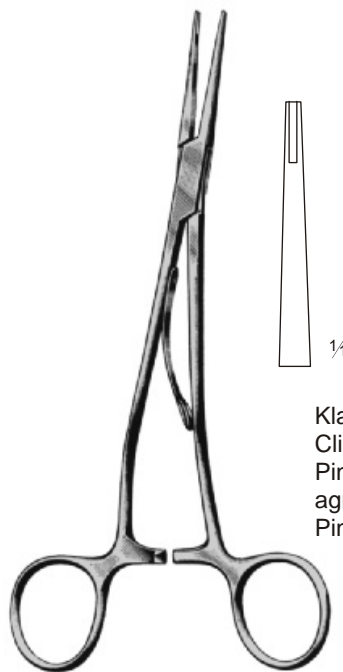

Klammer-Anlegezangen, gerade
 Clip Applying Forceps, straight
 Pinces pour appliquer des
 agrafes, droits
 Pinzas para poner grapas, rectas

McKenzie

18-1361-15 15,0 cm/6"
 18-1361-19 19,0 cm/7½"

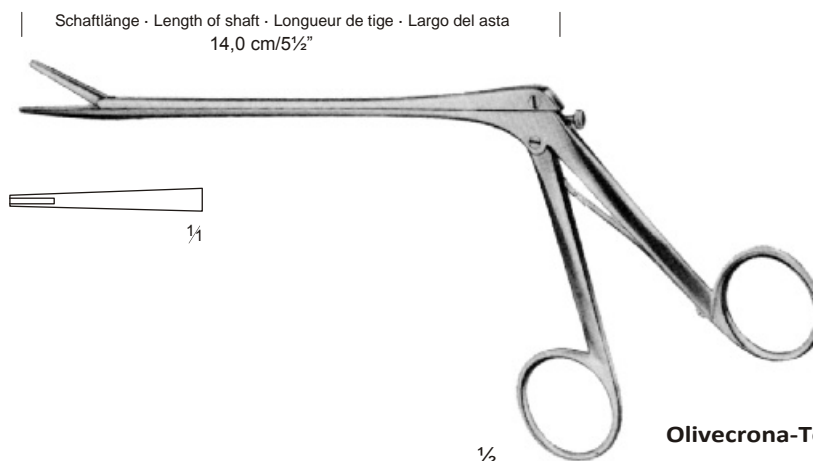

Olivecrona-Toennis

18-1362-14
 14,0 cm/5½"

Klammer-Anlegezange
 Clip Applying Forceps
 Pince pour appliquer des agrafes
 Pinza para poner grapa

Hirnspatel
Brain Spatulas
Spatules cérébrales
Espátulas cerebrales

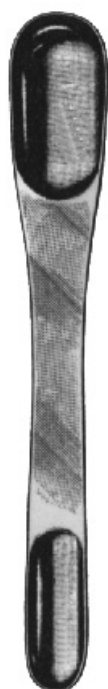

Cushing
 18,0 cm/7"

	mm
18-1364-01	7/ 9
18-1364-02	11/13
18-1364-03	15/18
18-1364-04	18/22



Heifetz
 biegsam, malleable
 malléable, maleable
 20,0 cm/8"

	mm
18-1365-08	8
18-1365-11	11
18-1365-14	14
18-1365-17	17
18-1365-20	20

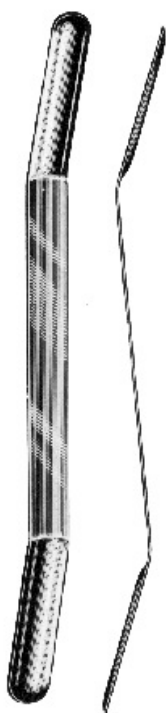

Olivecrona
 18,0 cm/7"

Spatelbreite, mm
 Width of spatulas, mm
 Largeur de spatule, mm
 Anchura de espátulas, mm

	oben upper end en haut arriba	unten lower end en bas abajo	
18-1366-01	7	9	18-1367-01
18-1366-02	11	13	18-1367-02
18-1366-03	15	18	18-1367-03
18-1366-04	18	22	18-1367-04

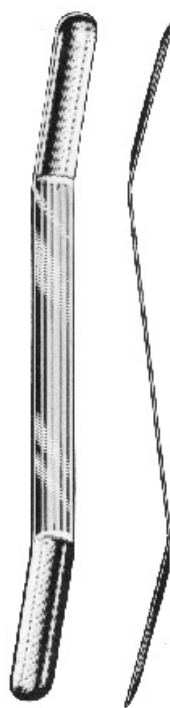

Explorations- und Koagulationshäkchen
Exploration- and Coagulation Hooks
Crochets d'exploration y coagulation
Ganchos para exploración y coagulación



Fig. 1
18-1369-01



Fig. 2
18-1369-02



Fig. 3
18-1369-03

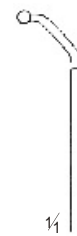

Fig. 4
18-1369-04

Caspar
24,5 cm/9¾"

geknöpft, isoliert
probe-end, insulated
boutonné, isolé
abotonado, aislado



Fadenführer
Ligature Guides
Passe-fils
Guía-ligaduras

Nerv- und Gefäßhäkchen
Nerve- and Vessel Hooks
Crochets à nerfs et à vaisseaux
Ganchos para nervios y vasos



Yasargil

Fig. 1
18-1370-01
18,5 cm/7¼"
Fadenführer, geknöpft
Ligature Guide, probe pointed
Passe-fil, boutonné
Guía-ligadura, abotonado

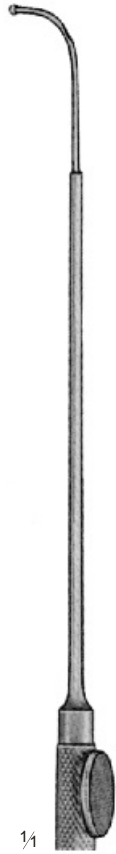

Fig. 2
18-1370-02



Fig. 3
18-1370-03



Fig. 4
18-1370-04



Krayenbühl

Fig. 1
18-1371-01
18,5 cm/7¼"
Nerv- und Gefäßhäkchen
Nerve- and Vessel Hooks
Crochets à nerfs et à vaisseaux
Ganchos para nervios y vasos



Fig. 2
18-1371-02



Fig. 3
18-1371-03



Fig. 4
18-1371-04



Mikro-Häkchen
Micro Hooks
Micro-Crochets
Micro-Ganchitos

Mikro-Raspatorien
Micro Raspatories
Micro-Rugines
Micro-Periostótomos

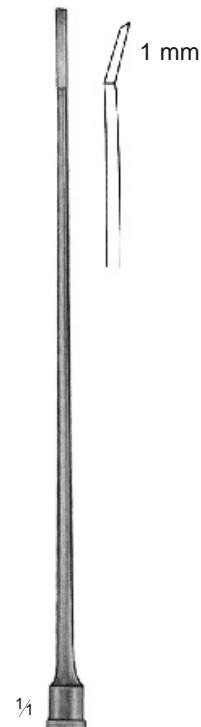

Fig. 1
18-1374-01

Fig. 2
18-1374-02

Fig. 3
18-1374-03

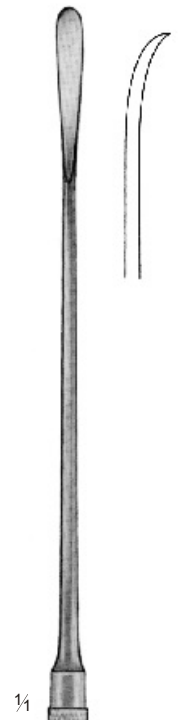
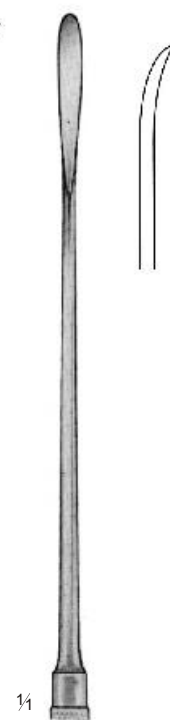

Fig. 4
18-1374-04

Fig. 5
18-1374-05

Fig. 6
18-1374-06

18-1372-19
18,5 cm/7¼"

Durahäkchen
Dura Hook
Crochet pour la dure-mère
Ganchito para dura-madre

Fisch

18-1373-19
18,5 cm/7¼"

Feines Häkchen
Delicate Hook
Crochet fin
Ganchito muy fino

Yasargil
18,5 cm/7¼"

Mikro-Raspator
Micro-raspatory
Micro-rugine
Micro-periostótomo

Mikro-Löffel
Micro Scoops
Micro-Curettes
Micro-Cucharillas

Mikro-Gabeln
Micro Forks
Micro-Fourches
Micro-Empujadores

Raspatorien
Raspatories
Rugines
Periostótomos



Yasargil
 18,5 cm/7¼"
 Fadengabel
 Suture pusher
 Fourche à fil
 Empujador de sutura

Fig. 1
 18-1375-01

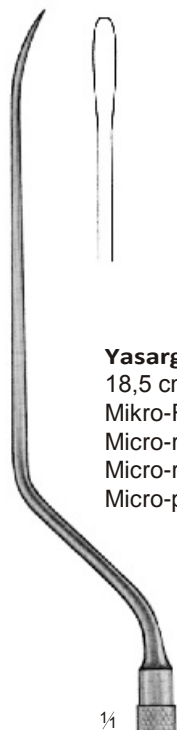

Yasargil
 18,5 cm/7¼"
 Mikro-Raspatorien
 Micro-raspatories
 Micro-rugines
 Micro-periostótomos

Fig. 2
 18-1375-02

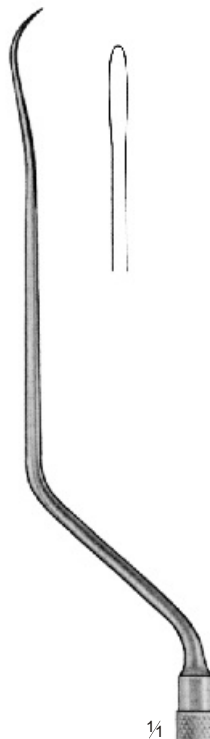

Fig. 3
 18-1375-03

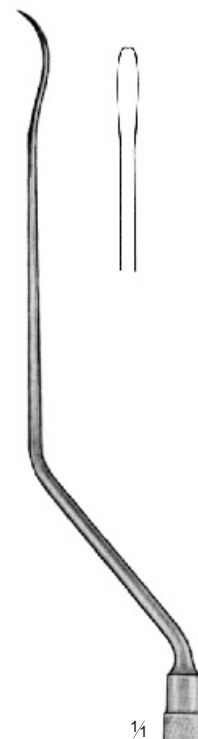

Fig. 4
 18-1375-04



Yasargil
 18,5 cm/7¼"
 Scharfer Löffel
 Scoop, bayonet-shaped
 Curette tranchante
 Cucharilla cortante

18-1376-19



Jakobson
 18,5 cm/7¼"
 Doppelsonde
 Twin Probe
 Sonde double
 Sonda doble

18-1377-19



Jacobson
 18,5 cm/7¼"
 Knopfsonde
 Buttoned Probe
 Sonde boutonée
 Sonda abotonada

18-1378-19



Mikro-Gefäßmesser
Micro Vessel Knives
Micro-Couteaux à vaisseaux
Micro-Cuchillos para vasos



1/4

Jacobson
 18-1379-19
 18,5 cm/7 1/4"

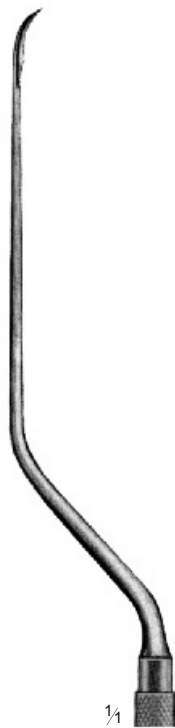

1/4

Koos
Fig. 1
 18-1380-01
 18,5 cm/7 1/4"



1/4

Koos
Fig. 2
 18-1380-02
 18,5 cm/7 1/4"



1/4

Koos
Fig. 3
 18-1380-03
 18,5 cm/7 1/4"

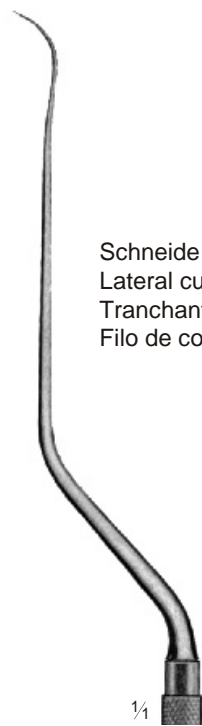

1/4

Schneide seitlich
Lateral cutting edge
Tranchant latéral
Filo de corte lateral

Kraus
 18-1381-19
 18,5 cm/7 1/4"

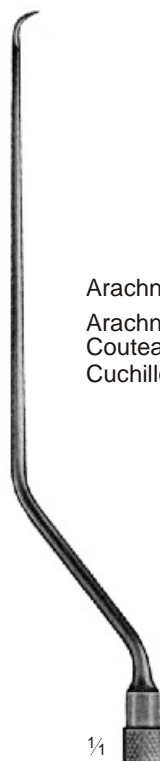

1/4

Arachnoidea-Messer
Arachnoid Knife
Couteau à arachnoïdes
Cuchillo para arachnoide

Yasargil
 18-1382-19
 18,5 cm/7 1/4"



Galeahaken
Galea Hooks
Crochets de galeati
Gancho para galea

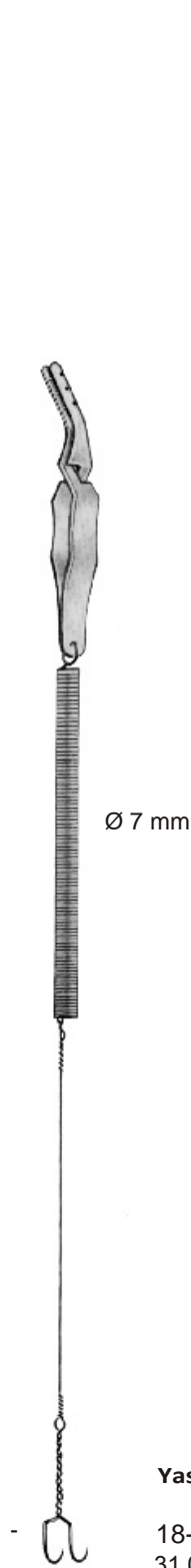
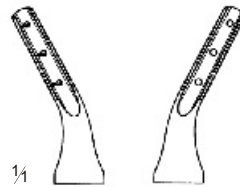

Yasargil
18-1395-01
31,0 cm/12 1/4"



Yasargil
18-1395-02
41,0 cm/16"



Dura-Dissektoren
Dura Dissectors
Dissecteurs à dure-mère
Disecadores para dura-madre

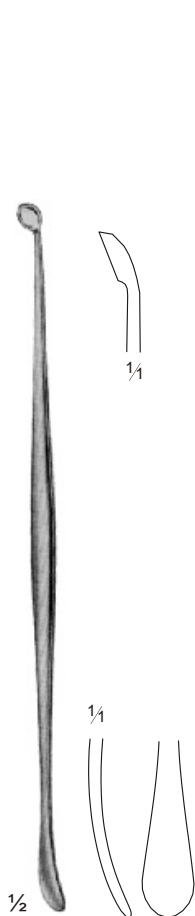

Penfield

Fig. 1
 18-1401-01
 18,0 cm/7"

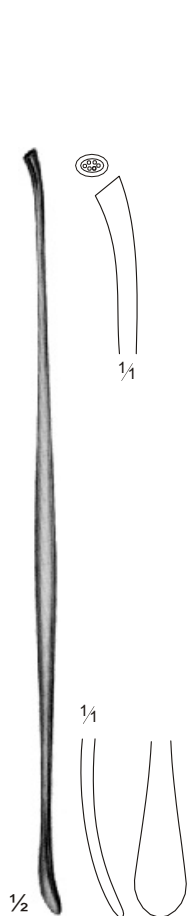

Penfield

Fig. 2
 18-1401-02
 20,0 cm/8"

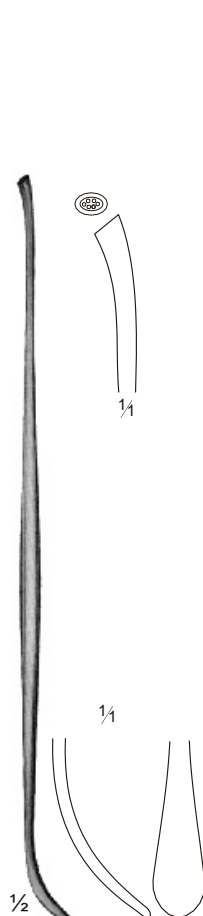

Penfield

Fig. 3
 18-1401-03
 20,0 cm/8"



Penfield

Fig. 4
 18-1401-04
 21,5 cm/8½"

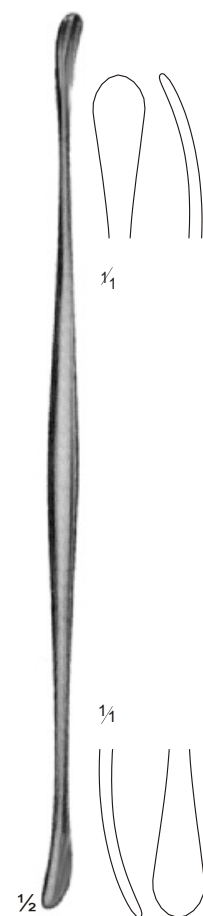

Penfield

Fig. 5
 18-1401-05
 29,0 cm/11½"

Dura-Dissektoren
Dura Dissectors
Dissecteurs à dure-mère
Disecadores para dura-madre

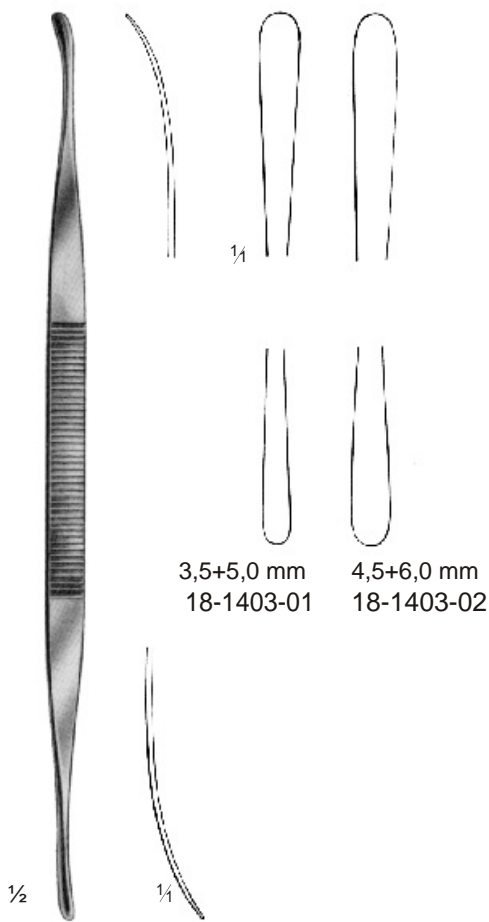

Toennis
 24,0 cm/9½"

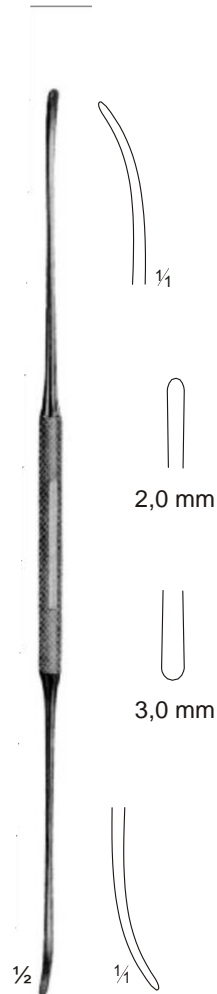

Olivecrona
 2 + 3 mm

18-1404-01 18,0 cm/7"
 18-1404-02 24,0 cm/9½"

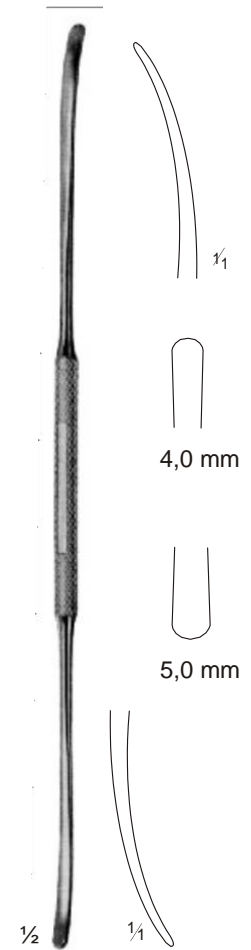

Olivecrona
 4 + 5 mm

18-1404-03 18,0 cm/7"
 18-1404-04 24,0 cm/9½"



Dura-Dissektoren
Dura Dissectors
Dissecteurs pour la dure-mère
Disecadores para dura-madre

Dura-Separatoren
Dura Dissectors
Dissecteurs pour la dure-mère
Descoladores de dura-madre

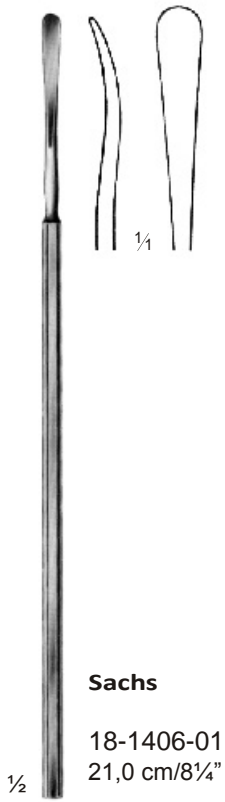

Sachs

18-1406-01
 21,0 cm/8 1/4"



Sachs

18-1406-02
 21,0 cm/8 1/4"

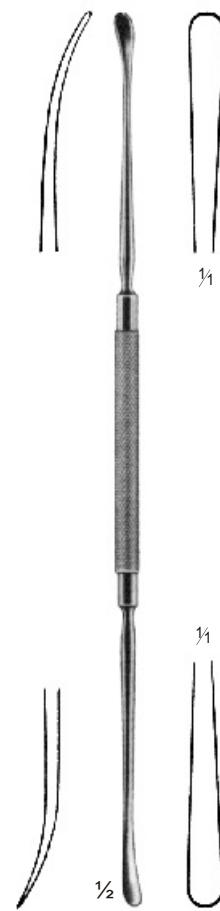

Davis
 4 mm

18-1407-24
 24,5 cm/9 3/4"

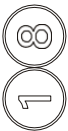

Frazier

18-1410-01
 15,0 cm/6"



Hoen

18-1410-02
 15,0 cm/6"



Hoen

18-1410-03
 15,0 cm/6"

Dura-Separatoren
Dura Dissectors
Dissecteurs pour la dure-mère
Descoladores de dura-madre

Nervwurzelnhaken
 Nerve Root Retractors
 Retracteurs pour racines nerveuses
 Separadores de raíz de nervios

Dura-Separatoren
 Dura Dissectors
 Dissecteurs pour la dure-mère
 Descoladores de dura-madre

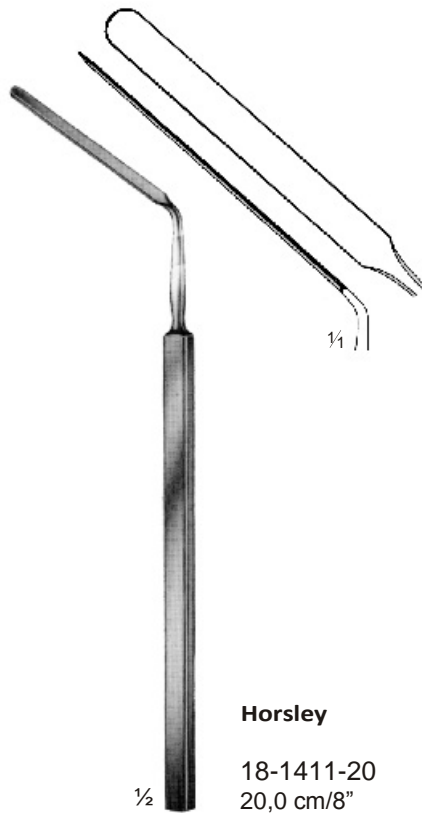

Dura Separator
 Dura Dissector
 Dissecteur pour la dure-mère
 Descolador de dura-madre

Horsley

18-1411-20
 20,0 cm/8"

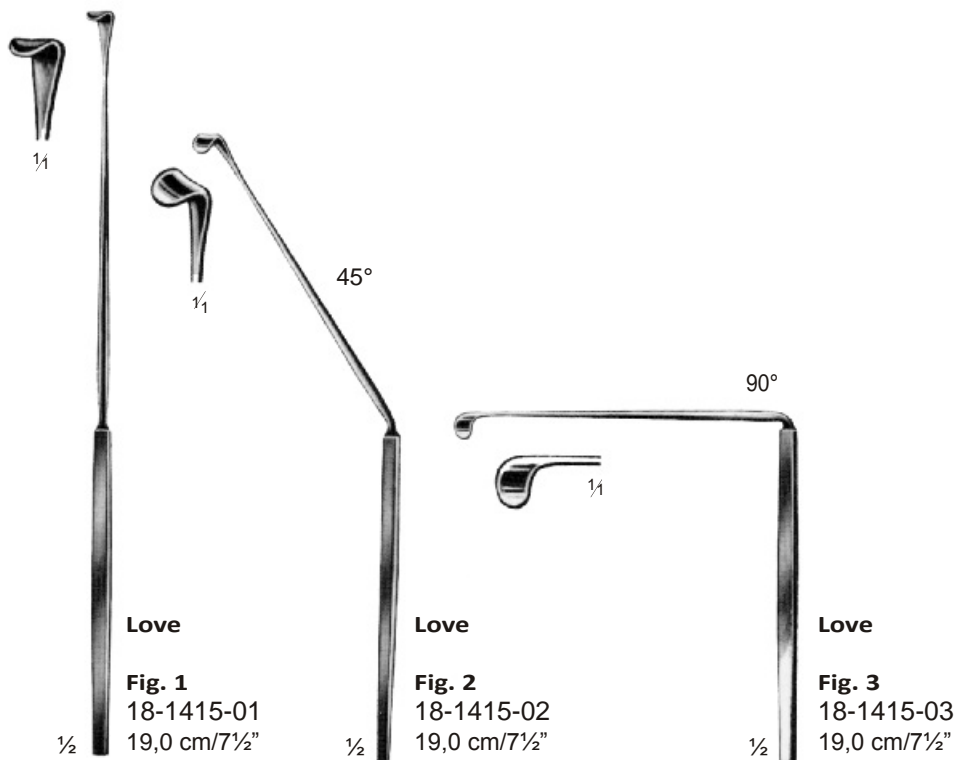

Love

Fig. 1
 18-1415-01
 19,0 cm/7½"

Love

Fig. 2
 18-1415-02
 19,0 cm/7½"

Love

Fig. 3
 18-1415-03
 19,0 cm/7½"



Nervwurzelhaken
Nerve Root Retractors
Retracteurs pour racines nerveuses
Separadores de raíz de nervios

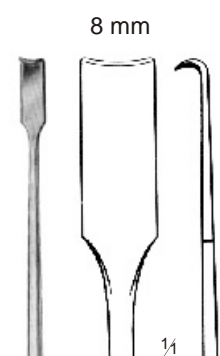

1/2

Scoville

18-1416-01
 23,0 cm/9"
 gerade, straight
 droit, recto

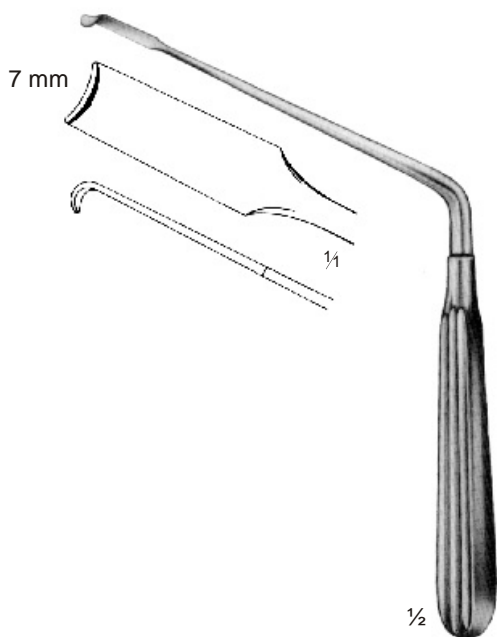

1/2

Scoville

18-1416-02
 20,0 cm/8"
 abgewinkelt, angular
 coudé, angular

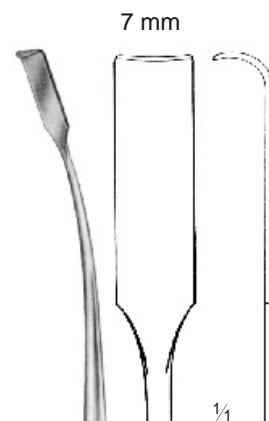

1/2

Holsher

18-1417-24
 24,0 cm/9 1/2"

Nervhaken
Nerve Hooks
Crochets à nerfs
Ganchos para nervios

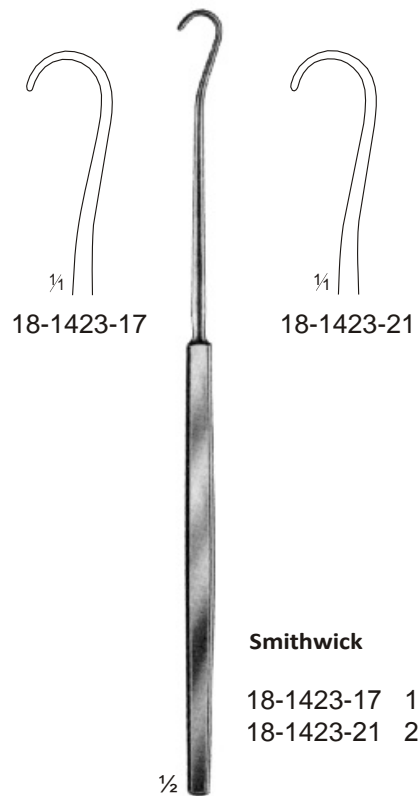
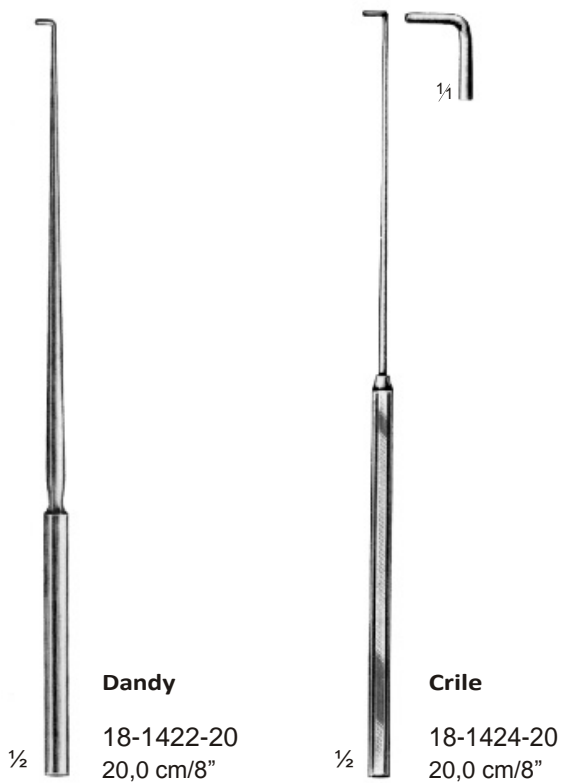
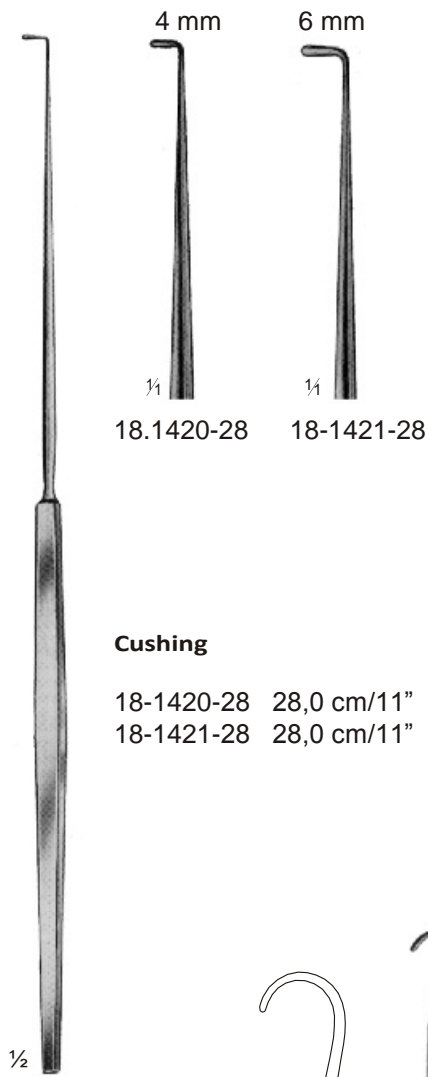
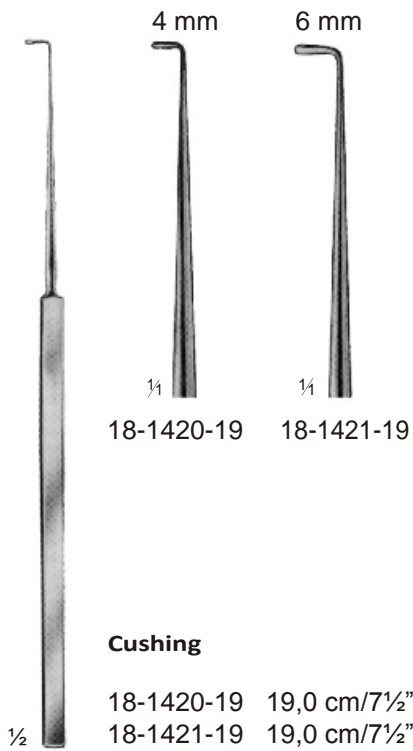

Dura- und Nervhaken
Dura and Nerve Hooks
Crochets à dure-mère et à nerfs
Ganchos para dura madre y nervios

Duramesser
Dura Knives
Bistouris à dure-mère
Bisturías para dura madre

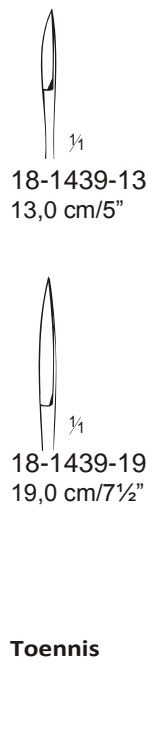
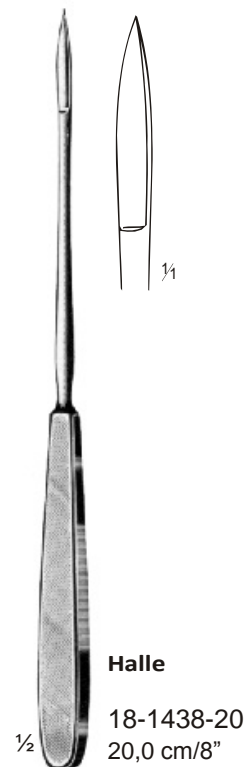
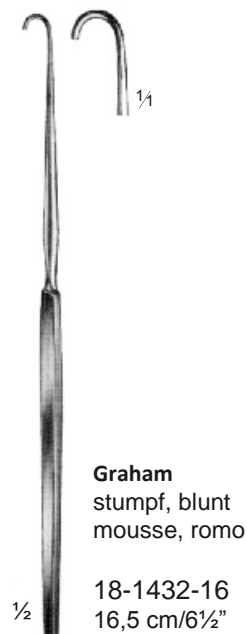
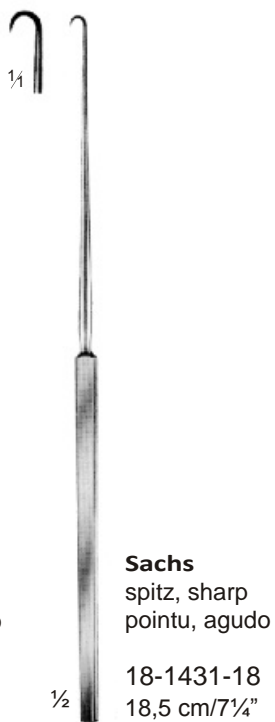
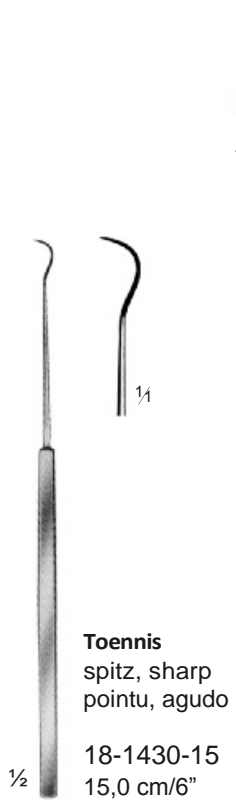
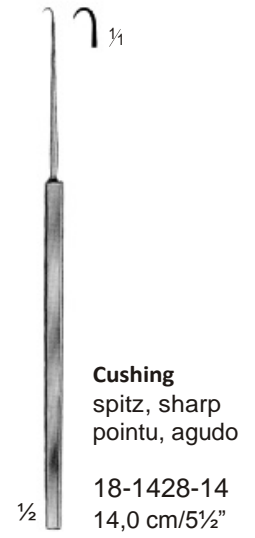
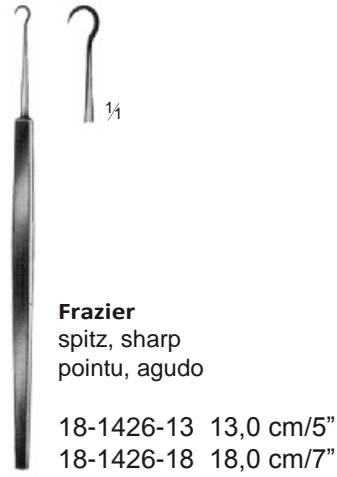

Bandscheiben-Rongeure
Intervertebral Disc Rongeurs
Pinces à disques vertébrales
Pinzas para discos vertebrales

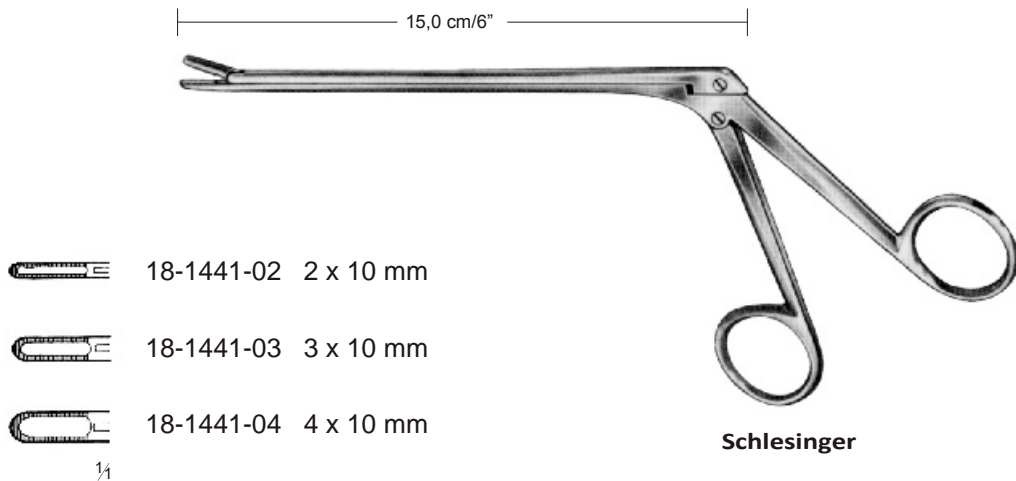
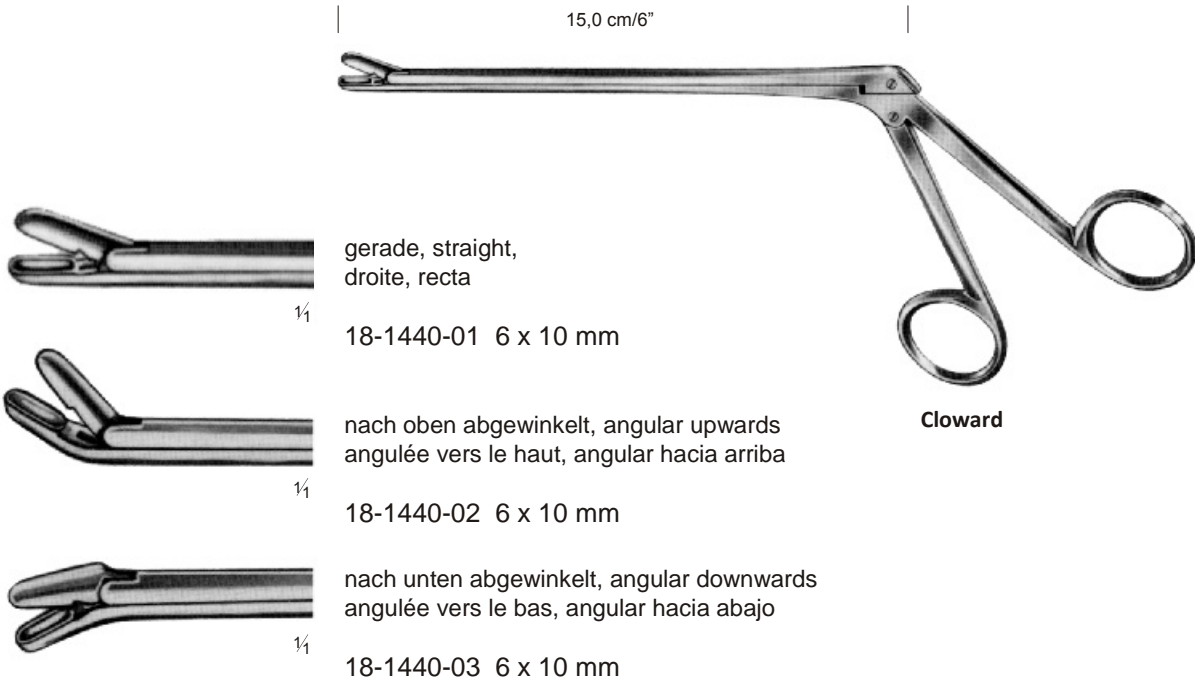

Laminektomie-Zangen
Laminectomy Rongeurs
Pinces emporte-pièces à laminectomie
Pinzas cortantes para laminectomia

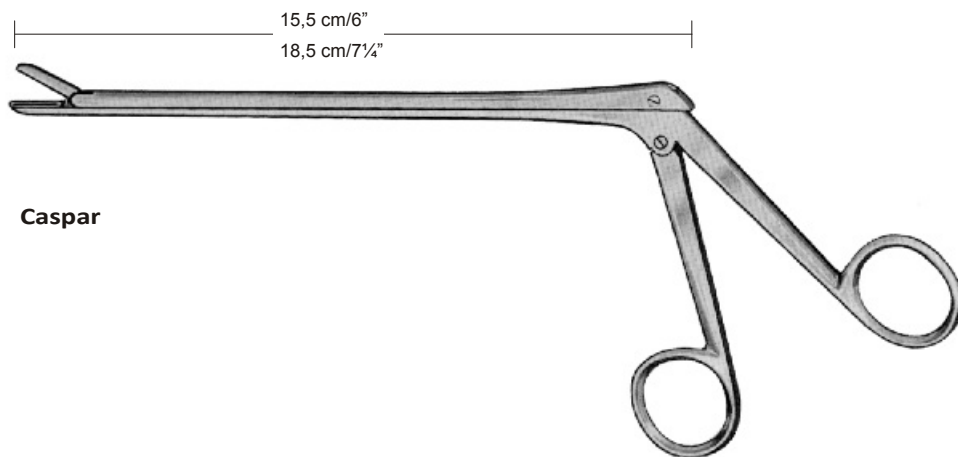

Caspar



	2 x 12 mm	3 x 12 mm	4 x 14 mm
15,5 cm/6"	18-1442-02	18-1442-03	18-1442-04
18,5 cm/7 1/4"	18-1443-02	18-1443-03	18-1443-04



	2 x 12 mm	3 x 12 mm	4 x 14 mm
15,5 cm/6"	18-1444-02	18-1444-03	18-1444-04
18,5 cm/7 1/4"	18-1445-02	18-1445-03	18-1445-04



	2 x 12 mm	3 x 12 mm	4 x 14 mm
15,5 cm/6"	18-1446-02	18-1446-03	18-1446-04
18,5 cm/7 1/4"	18-1447-02	18-1447-03	18-1447-04

Bandscheiben-Rongeure
Intervertebral Disc Rongeurs
Pinces à disques vertébrales
Pinzas para discos vertebrales

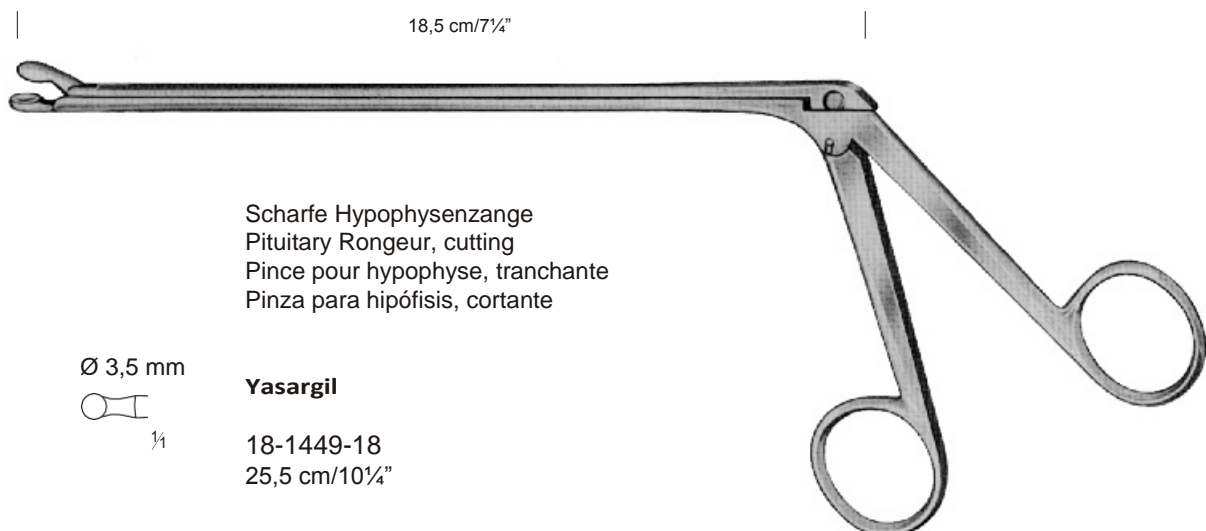
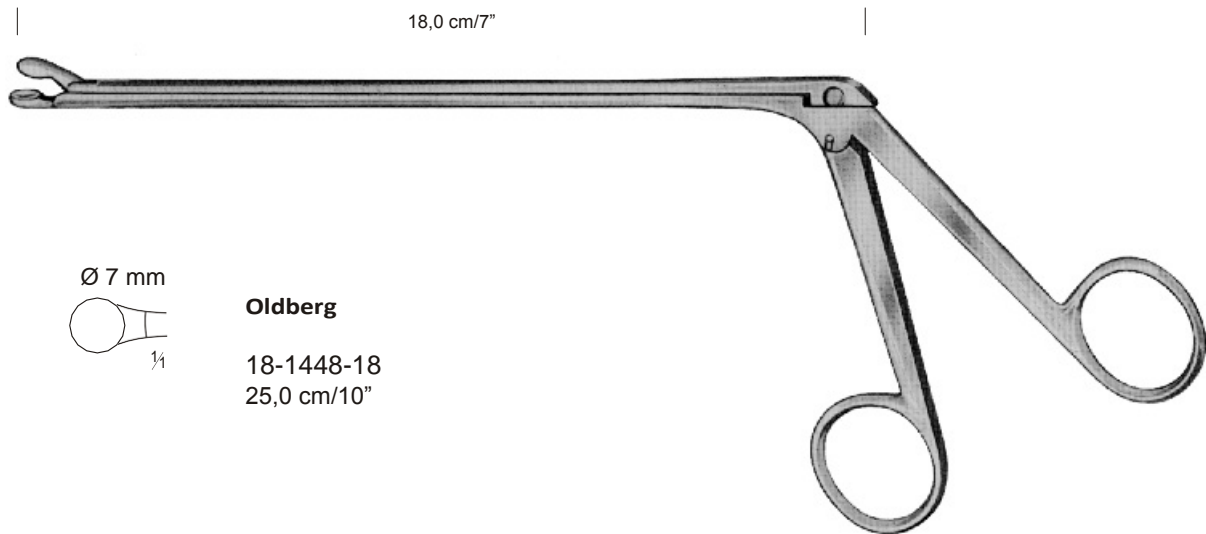
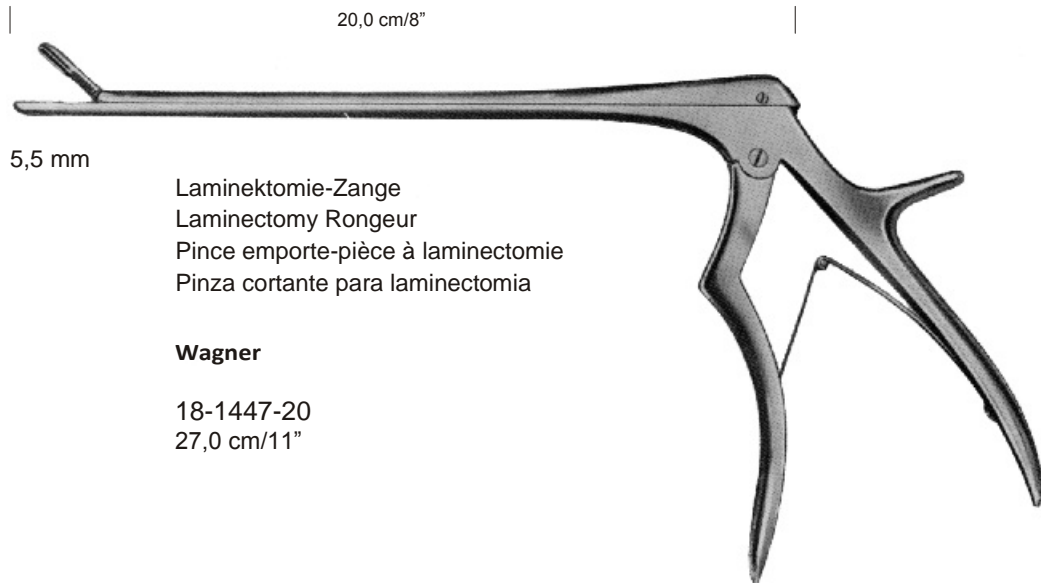

Bandscheiben-Rongeurs
Intervertebral Disc Rongeurs
Pinces à disques vertébrales
Pinzas para discos vertebrales

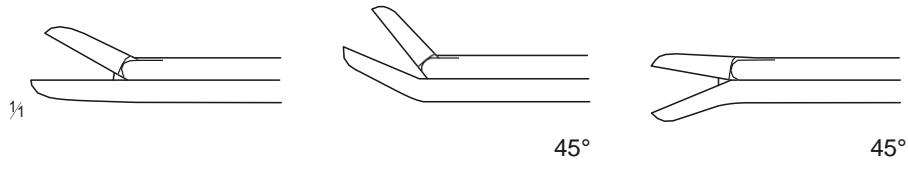
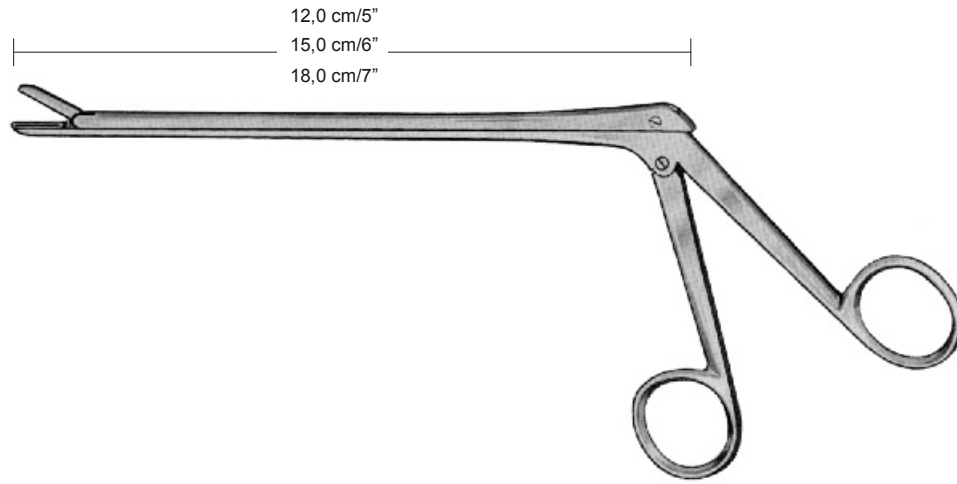

Cushing
2x10mm

12,0 cm/5"	18-1450-12	18-1451-12	18-1452-12
15,0 cm/6"	18-1450-15	18-1451-15	18-1452-15
18,0 cm/7"	18-1450-18	18-1451-18	18-1452-18

Love-Gruenwald
3 x 10mm

12,0 cm/5"	18-1460-12	18-1461-12	18-1462-12
15,0 cm/6"	18-1460-15	18-1461-15	18-1462-15
18,0 cm/7"	18-1460-18	18-1461-18	18-1462-18

Spurling
4 x 10mm

12,0 cm/5"	18-1470-12	18-1471-12	18-1472-12
15,0 cm/6"	18-1470-15	18-1471-15	18-1472-15
18,0 cm/7"	18-1470-18	18-1471-18	18-1472-18

Bandscheiben-Rongeur
Intervertebral Disc Rongeurs
Pinces à disques vertébrales
Pinzas para discos vertebrales



Ferris-Smith-Kerrison

reguläres Modell
 regular pattern
 modèle regulier
 modelo regular

zerlegbares Model
 dismantable pattern
 modèle démontable
 modelo desmontable

		Bißbreite Width of bite Grandeur de coupe Ancho de la boca	Schaftlänge , Length of shaft Longueur de tige, Largo del asta		Schaftlänge , Length of shaft Longueur de tige, Largo del asta	
			18,0 cm/7"	20,0 cm/8"	18,0 cm/7"	20,0 cm/8"
90° nach oben schneidend 90° upwards cutting coupante vers le haut 90° cortante hacia arriba 90°		1 mm	18-1480-01	18-1481-01	18-1486-01	18-1487-01
		2 mm	18-1480-02	18-1481-02	18-1486-02	18-1487-02
		3 mm	18-1480-03	18-1481-03	18-1486-03	18-1487-03
		4 mm	18-1480-04	18-1481-04	18-1486-04	18-1487-04
		5 mm	18-1480-05	18-1481-05	18-1486-05	18-1487-05
		6 mm	18-1480-06	18-1481-06	18-1486-06	18-1487-06

		Bißbreite Width of bite Grandeur de coupe Ancho de la boca	Schaftlänge , Length of shaft Longueur de tige, Largo del asta		Schaftlänge , Length of shaft Longueur de tige, Largo del asta	
			18,0 cm/7"	20,0 cm/8"	18,0 cm/7"	20,0 cm/8"
40° nach oben schneidend 40° upwards cutting coupante vers le haut 40° cortante hacia arriba 40°		1 mm	18-1482-0	18-1483-01	18-1488-01	18-1489-01
		2 mm	18-1482-02	18-1483-02	18-1488-02	18-1489-02
		3 mm	18-1482-03	18-1483-03	18-1488-03	18-1489-03
		4 mm	18-1482-04	18-1483-04	18-1488-04	18-1489-04
		5 mm	18-1482-05	18-1483-05	18-1488-05	18-1489-05
		6 mm	18-1482-06	18-1483-06	18-1488-06	18-1489-06

Bandscheiben-Rongeure
Intervertebral Disc Rongeurs
Pinces à disques vertébrales
Pinzas para discos vertebrales

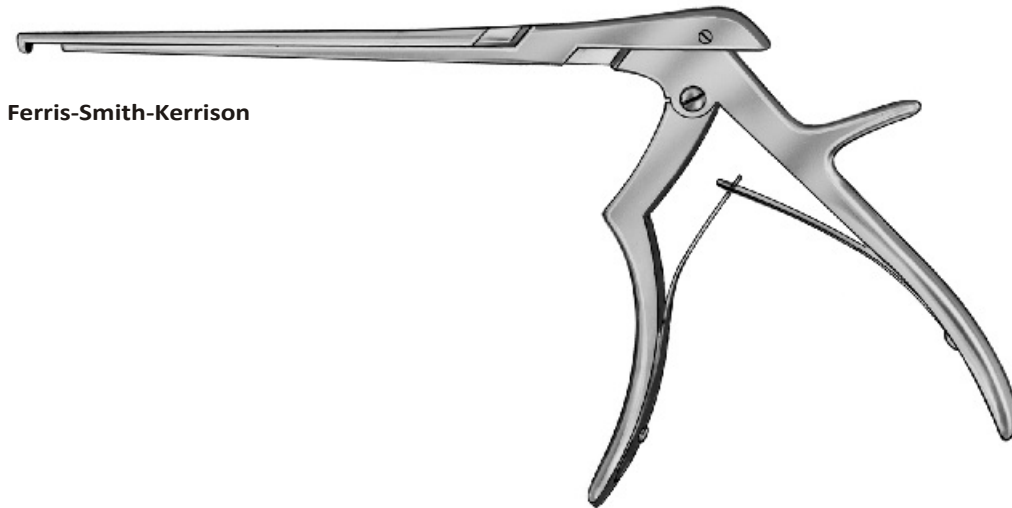

Ferris-Smith-Kerrison

90° nach unten schneidend
 90° downwards cutting
 coupante vers le bas 90°
 cortante hacia abajo 90°

Bißbreite
 Width of bite
 Grandeur de coupe
 Ancho de la boca

Schaftlänge , Length of shaft
 Longueur de tige, Largo del asta

1/4

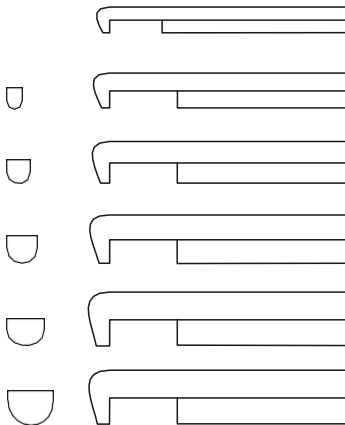



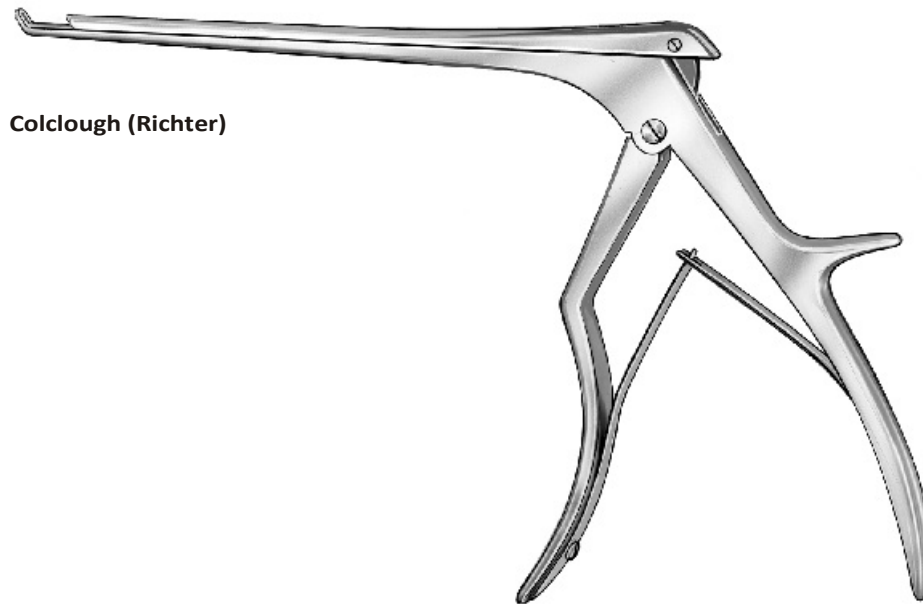

	18,0 cm/7"	20,0 cm/8"
1 mm	18-1484-01	18-1485-01
2 mm	18-1484-02	18-1485-02
3 mm	18-1484-03	18-1485-03
4 mm	18-1484-04	18-1485-04
5 mm	18-1484-05	18-1485-05
6 mm	18-1484-06	18-1485-06

Bandscheibenstanzen
Intervertebral Disc Rongeurs
Pinces à disques vertébrales
Pinzas cortantes para discos intervertebrales



Colclough (Richter)

		Bißbreite Width of bite Grandeur de coupe Ancho de laboca	Schaftlänge , Length of shaft Longueur de tige, Largo del asta		
			15,0 cm/6"	18,0 cm/7"	20,0 cm/8"
1/4		2 mm	18-1502-15	18-1502-18	18-1502-20
		3 mm	18-1503-15	18-1503-18	18-1503-20
		4 mm	18-1504-15	18-1504-18	18-1504-20
		5 mm	18-1505-15	18-1505-18	18-1505-20
		6 mm	18-1506-15	18-1506-18	18-1506-20



Bandscheibenstanzen
Intervertebral Disc Rongeurs
Pinces à disques vertébrales
Pinzas cortantes para discos intervertebrales



Colclough (Richter)

40° nach oben schneidend 40° upwards cutting coupante vers le haut 40° cortante hacia arriba 40°		Bißbreite Width of bite Grandeur de coupe Ancho de la boca	Schaftlänge , Length of shaft Longueur de tige, Largo del asta		
			15,0 cm/6"	18,0 cm/7"	20,0 cm/8"
		2 mm	18-1512-15	18-1512-18	18-1512-20
		3 mm	18-1513-15	18-1513-18	18-1513-20
		4 mm	18-1514-15	18-1514-18	18-1514-20
		5 mm	18-1515-15	18-1515-18	18-1515-20
		6 mm	18-1516-15	18-1516-18	18-1516-20

90° nach unten schneidend 90° downwards cutting coupante vers le bas 90° cortante hacia abajo 90°		Bißbreite Width of bite Grandeur de coupe Ancho de la boca	Schaftlänge , Length of shaft Longueur de tige, Largo del asta		
			15,0 cm/6"	18,0 cm/7"	20,0 cm 8"
		2 mm	18-1522-15	18-1522-18	18-1522-20
		3 mm	18-1523-15	18-1523-18	18-1523-20
		4 mm	18-1524-15	18-1524-18	18-1524-20
		5 mm	18-1525-15	18-1525-18	18-1525-20
		6 mm	18-1526-15	18-1526-18	18-1526-20

Laminektomiespreizer
Laminectomy Spreaders
Ecarteurs pour laminectomie
Separadores para laminectomia

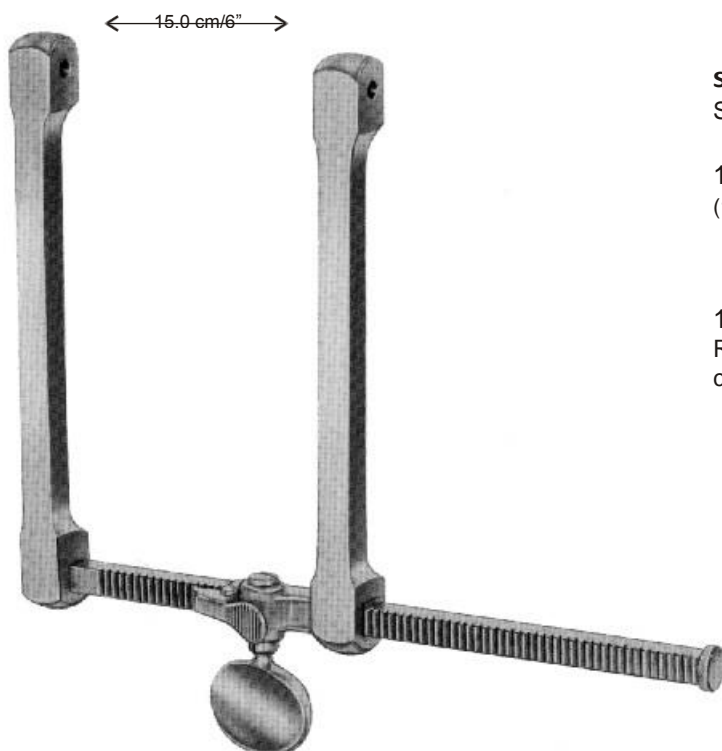

Scoville

Set, set, série, juego

18-1540-00

(1 x 18-1540-01, 1 x 18-1543-50, 1 x 18-1545-01)

18-1540-01

Rahmen allein, frame only,
cadre seul, cuadro solo

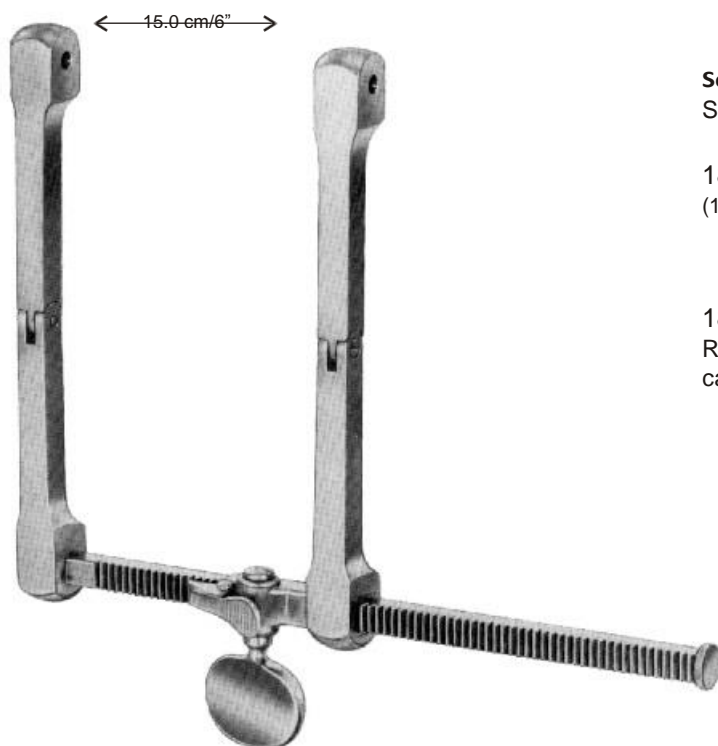

Scoville-Haverfield

Set, set, série, juego

18-1541-00

(1 x 18-1541-01, 1 x 18-1543-50, 1 x 18-1545-01)

18-1541-01

Rahmen allein, frame only,
cadre seul, cuadro solo



Laminektomiespreizer
Laminectomy Spreaders
Ecarteurs pour laminectomie
Separadores para laminectomia



Haken, Hooks, Crochets, Separadores



Scoville
 stumpf, blunt
 mousse, romo

- 18-1543-50 50 mm/2"
- 18-1543-70 70 mm/2¾"
- 18-1543-75 75 mm/3"



Scoville
 spitz, sharp
 pointu, agudo

- 18-1544-50 50 mm/2"
- 18-1544-70 70 mm/2¾"
- 18-1544-75 75 mm/3"

Valven, Blades, Valves, Valvas



Scoville

- 18-1545-01 64 x 25 mm
- 18-1545-02 64 x 29 mm
- 18-1545-03 64 x 50 mm
- 18-1545-04 88 x 25 mm



Taylor

- 18-1546-01 38 x 44 mm



Taylor

- 18-1547-01 48 x 50 mm
- 18-1547-02 64 x 50 mm
- 18-1547-03 64 x 64 mm
- 18-1547-04 80 x 57 mm

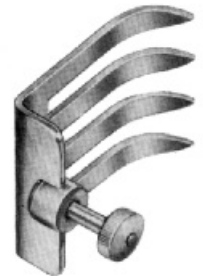

Scoville

- 18-1548-01 41 x 38 mm
- 18-1548-02 67 x 44 mm



Taylor

- 18-1549-01 32 x 75 mm
- 18-1549-02 42 x 100 mm

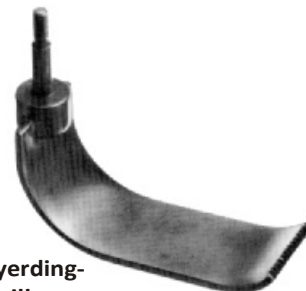

Meyerding-Scoville

- 18-1550-01 50 x 25 mm
- 18-1550-02 70 x 25 mm
- 18-1550-03 83 x 25 mm

gezahnt
 saw edge
 dentelée
 dentada

Laminektomiespreizer
Laminectomy Spreaders
Ecarteurs pour laminectomie
Separadores para laminectomia



Cloward

18-1560-01 25,0 cm/9½"
 Sperrer allein, spreader only
 ecarteur seule, separador solo

18-1560-00
 Set mit 5 gezahnten Valven 18-1561-40 - 18-1561-60
 Set with 5 toothed blades 18-1561-40 - 18-1561-60
 Jeu avec 5 valves dentelées 18-1561-40 - 18-1561-60
 Juego con 5 valvas dentadas 18-1561-40 - 18-1561-60



Valve, gezahnt
 Blade, saw edge
 Valve, dentelée
 Valva, dentada

18-1561-40 40 mm
 18-1561-45 45 mm
 18-1561-50 50 mm
 18-1561-55 55 mm
 18-1561-60 60 mm



Cloward

18-1562-01 17,0 cm/6¾"
 Sperrer allein, spreader only
 ecarteur seule, separador solo

18-1562-00
 Set mit 5 stumpfen Valven 18-1562-40 - 18-1562-60
 Set with 5 blunt blades 18-1562-40 - 18-1562-60
 Jeu avec 5 valves mouses 18-1562-40 - 18-1562-60
 Juego con 5 valvas romas 18-1562-40 - 18-1562-60



Valve, stumpf
 Blade, blunt
 Valve, mousse
 Valva, roma

18-1562-40 40 mm
 18-1562-45 45 mm
 18-1562-50 50 mm
 18-1562-55 55 mm
 18-1562-60 60 mm



**Verschiedene Nagelinstrumente
Miscellaneous Nail Instruments
Instruments divers pour les ongles
Instrumentos diversos para las uñas**



19

Nagelinstrumente
Nail Instruments
Instrumente à ongles
Instrumentos para uñas



Nagelfeile
Nail File
Lime à ongles
Lima para uñas

19-1620 10,0 cm/4"
19-1621 12,0 cm/4¾"



Nagelfeile
Nail File
Lime à ongles
Lima para uñas

19-1622 11,0 cm/4½"



19-1625
Schwestern Set
Set for nurses
Jeu pour une infirmière
Juego para una enfermera

Haut- und Nagelinstrumente
 Cuticle- and Nail Instruments
 Instruments à ongles et à envies
 Instrumentos para uñas y cuticulares

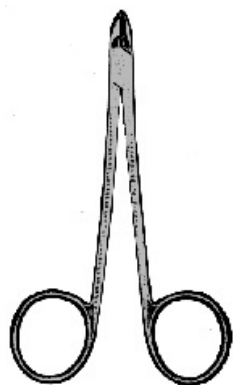

19-1628
 10,0 cm/4"
 Hautzange
 Cuticle Nippers
 Pince à envies
 Pinza para cuticulares

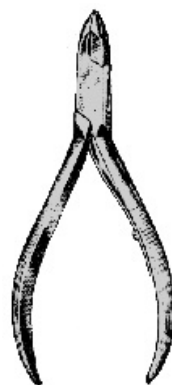

19-1629
 10,5 cm/4¼"
 Hautzange
 Cuticle Nippers
 Pince à envies
 Pinza para cuticulares



19-1630
 14,5 cm/5¾"
 Pedicure-Zange
 Nail Nippers
 Pincés à ongles
 Alicates corta-uñas



19-1631
 14,5 cm/5¾"
 Kopfschneider
 Nail Nippers
 Pincés à ongles
 Alicates corta-uñas

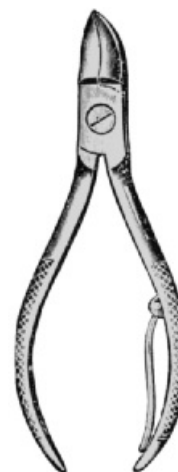

19-1632
 13,0 cm/5"
 Nagelzange
 Nail Nippers
 Pincés à ongles
 Alicates corta-uñas

109

Nagelinstrumente
Nail Instruments
Instruments à ongles
Instrumentos para uñas



19-1633
 12,0 cm/4³/₄"
 Nagelzange
 Nail Nippers
 Pincès à ongles
 Alicates corta-uñas



19-1634 12,0 cm/4³/₄"
 19-1635 13,5 cm/5¹/₄"
 Nagelzange
 Nail Nippers
 Pincès à ongles
 Alicates corta-uñas



19-1636
 13,0 cm/5"
 Nagelzange
 Nail Nippers
 Pincès à ongles
 Alicates corta-uñas

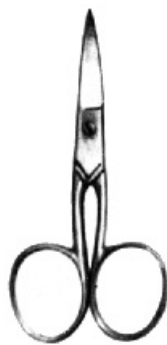

Nagelschere
 Nail Scissors
 Ciseaux à ongles
 Tijeras para uñas

19-1638 9,0 cm/3¹/₂"
 19-1639 10,5 cm/4¹/₂"
 gebogen
 curved
 courbes
 curvas



Nagelschere
 Nail Scissors
 Ciseaux à ongles
 Tijeras para uñas

19-1640 9,0 cm/3¹/₂"
 gebogen
 curved
 courbes
 curvas



Fingerringsägen
Finger Ring Saws
Scies pour bagues
Sierras para abrir anillos

Nagelinstrumente
Nail Instruments
Instruments à ongles
Instrumentos para uñas



19-1641
 17,0 cm/6³/₄"
 Fingerring-Säge
 Finger Ring Saw
 Scie pour bagues
 Sierra para abrir anillos



19-1642
 16,0 cm/6¹/₄"
 Fingerring-Säge, verchromt
 Finger Ring Saw, chrome plated
 Scie pour bagues, chromée
 Sierra para abrir anillos, cromada

19-1643
 Sägeblatt
 Saw blade
 Lame de scie
 Hoja de sierra

19-1644
 Sägeblatt
 Saw blade
 Lame de scie
 Hoja de sierra



19-1651
 Bohrer, Satz
 Drill, set
 Perforateurs, jeu
 Perforadores, juego



19-1650
 Fingernagel-Bohrer, Satz
 Finger nail drill, set
 Perforateurs pour les ongles, jeu
 Perforadores para uñas, juego



19-1652
 14,0 cm/5¹/₂"
 Nagelausreißzange
 Forceps for tearing out toe and finger nails
 Pincers pour l'extraction des ongles
 Pinzas para arrancar uñas



Feldmann
 19-1653
 10,0 cm/4"
 Finger- und Zehenkompressorium
 Tourniquet for fingers and toes
 Appareil à compression pour les doigts et les orteils
 Compresor para los dedos de la mano y del pie

**Scheren, Supercut-Scheren
Scissors, Supercut Scissors
Ciseaux, Ciseaux Supercut
Tijeras, Tijeras Supercut**



Chirurgische Scheren
Operating Scissors
Ciseaux à chirurgie
Tijeras para cirugía



Standard

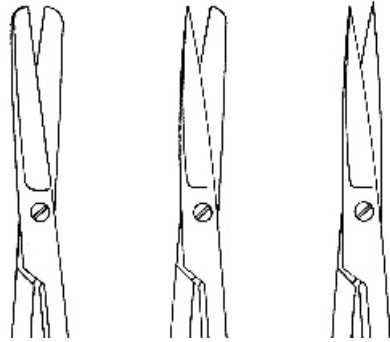

Fig. 1	Fig. 2	Fig. 3
20-1701	20-1711	20-1721
20-1702	20-1712	20-1722
20-1703	20-1713	20-1723
20-1704	20-1714	20-1724
20-1705	20-1715	20-1725
20-1706	20-1716	20-1726
20-1707	20-1717	20-1727
20-1708	20-1718	20-1728
20-1709	20-1719	20-1729



Standard

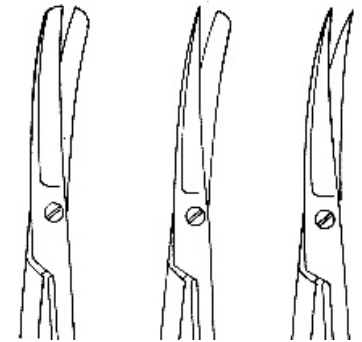

Fig. 1	Fig. 2	Fig. 3
10,5 cm/4¼"	20-1731	20-1741
11,5 cm/4½"	20-1732	20-1742
13,0 cm/5"	20-1733	20-1743
14,5 cm/5½"	20-1734	20-1744
15,5 cm/6"	20-1735	20-1745
16,5 cm/6½"	20-1736	20-1746
17,5 cm/7"	20-1737	20-1747
18,5 cm/7¼"	20-1738	20-1748
20,0 cm/8"	20-1739	20-1749

20



Grazil

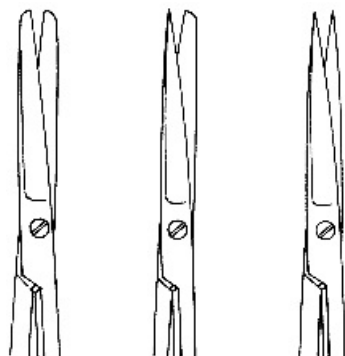

Fig.1	Fig. 2	Fig. 3
20-1761	20-1763	20-1765
20-1762	20-1764	20-1766



Grazil

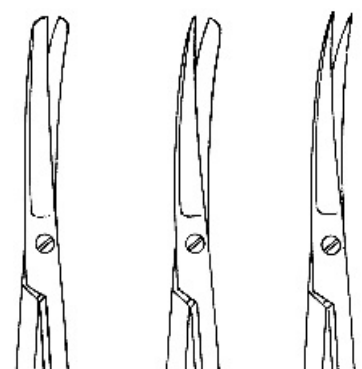

Fig. 1	Fig. 2	Fig. 3
13,0 cm/5"	20-1767	20-1771
14,5 cm/5½"	20-1768	20-1772

Chirurgische Scheren
Operating Scissors
Ciseaux à chirurgie
Tijeras para cirugía



20-1773

20-1775
 gezahnt
 saw edge
 dentelés
 dentadas

Deaver
 14,5 cm/5½"

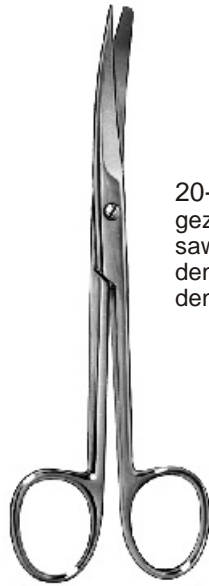

20-1774

20-1776
 gezahnt
 saw edge
 dentelés
 dentadas

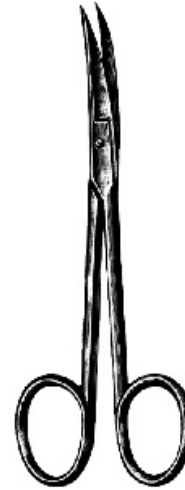

Goldmann-Fox
 13,0 cm/5"

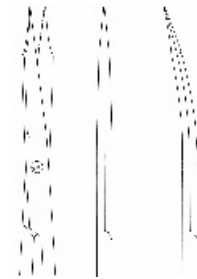

20-1777-01 20-1777-02

Inzisionsschere
Incision Scissors
Ciseaux à incision
Tijeras para incisión



20-1780 13,0 cm/5"
 20-1781 14,5 cm/5½"



Richter
 20-1783 14,5 cm/5½"



20-1785

20-1787
 gezahnt
 saw edge
 dentelés
 dentadas

Mixter
 15,5 cm/6"



20-1786

20-1788
 gezahnt
 saw edge
 dentelés
 dentadas

Präparierscheren
Dissecting Scissors
Ciseaux à dissection
Tijeras para preparaciones



20- 1791
 20- 1792
 20- 1793
 20- 1794

Mayo
 14,5 cm/5½"
 15,0 cm/6"
 17,0 cm/6¾"
 23,0 cm/9"



20- 1796
 20- 1797
 20- 1798
 20-1799



20-1801
 20-1802
 20-1802-21

Mayo-Stillé
 15,0 cm/6"
 17,0 cm/6¾"
 21,0 cm/8¼"



20-1803
 20-1804
 20-1804-21



20-1806

Mayo-Noble
 17,0 cm/6¾"



20-1808



20-1810

Mayo-Harrington
 23,0 cm/9"

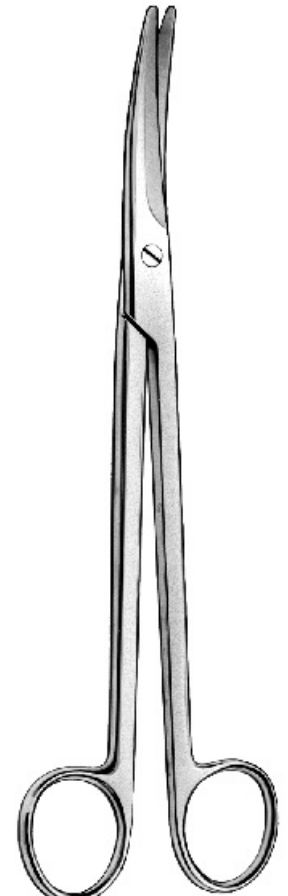

20-1811

20

Präparierscheren
Dissecting Scissors
Ciseaux à dissection
Tijeras para preparaciones



20-1812
20-1814

Bauchdecken-Scheren
Abdominal Scissors
Ciseaux abdominaux
Tijeras abdominales

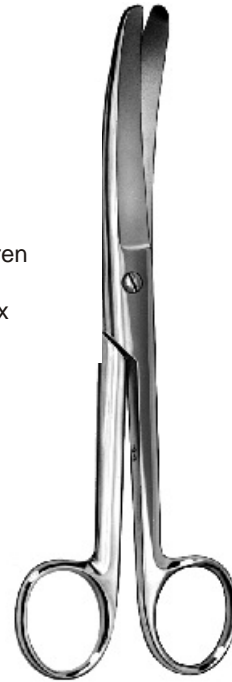

20-1813
20-1815

Doyen
16,0 cm/6¼"
17,5 cm/7"



20-1817



20-1818

Mayo-Lexer
16,0 cm/6¼"



20-1819



20-1820

Baby-Lexer
10,0 cm/4"

Präparierscheren
Dissecting Scissors
Ciseaux à dissection
Tijeras para preparaciones

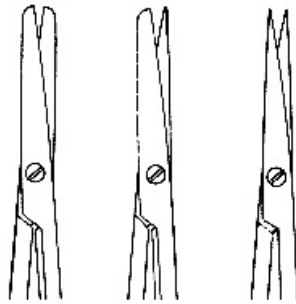

Fig. 1 20-1821 **Fig. 2** 20-1831 **Fig. 3** 20-1841

Metzenbaum
14,5 cm/5½"

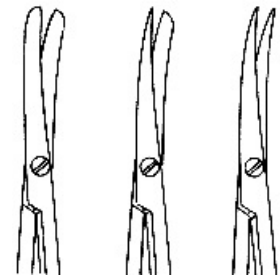

Fig. 1 20-1851 **Fig. 2** 20-1861 **Fig. 3** 20-1871

Metzenbaum
14,5 cm/5½"

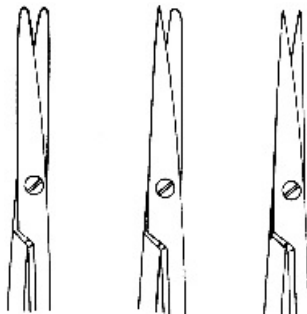
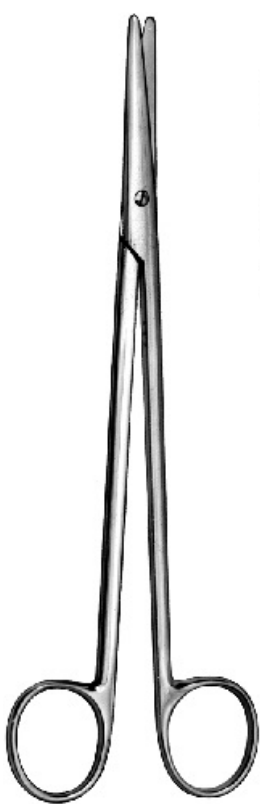

Fig. 1 20-1822 **Fig. 2** 20-1832 **Fig. 3** 20-1842
 20-1823 20-1833 20-1843
 20-1824 20-1834 20-1844
 20-1825 20-1835 20-1845
 20-1826 20-1836 20-1846
 20-1827 20-1837 20-1847

Metzenbaum

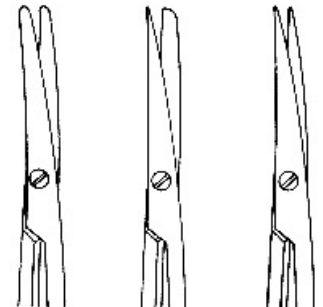
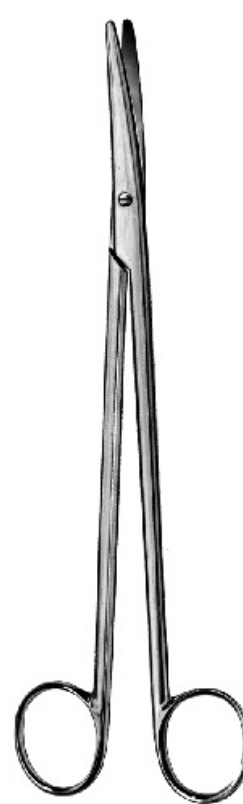

Fig. 1 20-1852 **Fig. 2** 20-1862 **Fig. 3** 20-1872
 20-1853 20-1863 20-1873
 20-1854 20-1864 20-1874
 20-1855 20-1865 20-1875
 20-1856 20-1866 20-1876
 20-1857 20-1867 20-1877

Metzenbaum

18,0 cm/7"
 20,0 cm/8"
 23,0 cm/9"
 25,0 cm/10"
 28,0 cm/11"
 30,0 cm/12"

20

Präparierscheren
Dissecting Scissors
Ciseaux à dissection
Tijeras para preparaciones

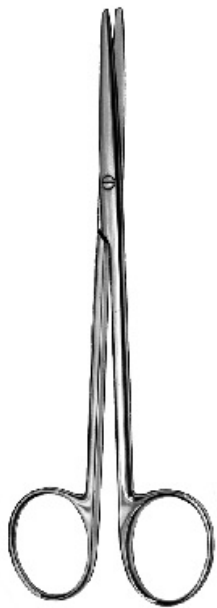

20-1880
 20-1881
 20-1882

Metzenbaum, Fino
 14,5 cm/5½"
 15,0 cm/6"
 18,0 cm/7"



20-1884
 20-1885
 20-1886



20-1887-01



Metzenbaum-Lahey
 14,0 cm/4¾" 20-1887-02

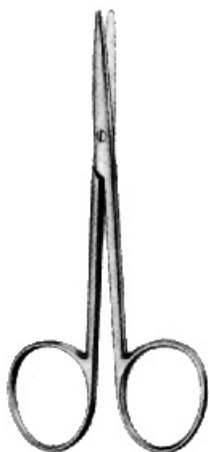

Metzenbaum
(Strabismus)
 11,5 cm/4½"



20-1888

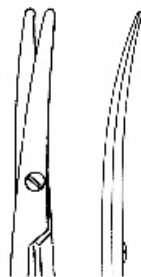

20-1889



Chirurgische und gynäkologische Schere
 Operating and gynecological Scissors
 Ciseaux à chirurgie et à gynécologie
 Tijeras para cirugía y ginecología

Wertheim
 20-1890 14,5 cm/5½"
 20-1891 19,5 cm/7¾"
 20-1892 22,5 cm/9"

Chirurgische und gynäkologische Scheren
 Operating and Gynecological Scissors
 Ciseaux à chirurgie et à gynécologie
 Tijeras para cirugía y ginecología



Sims

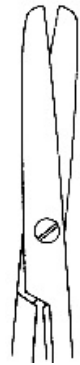
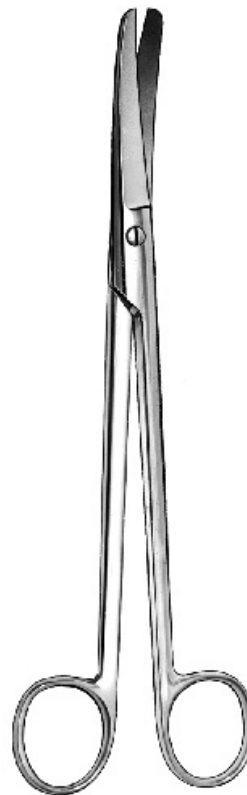

Fig. 1
 20-1893 20,0 cm/8"
 20-1895 23,0 cm/9"



Fig. 2
 20-1896 20-1898



Sims



Fig. 1
 20-1899 20,0 cm/8"
 20-1901 23,0 cm/9"



Fig. 2
 20-1902 20-1904



20-1905-16
 20-1905-18

Feine Scheren
 Delicate Scissors
 Ciseaux fins
 Tijeras finas



Kelly
 16,0 cm/6¼"
 18,0 cm/7"
 20-1906-16
 20-1906-18

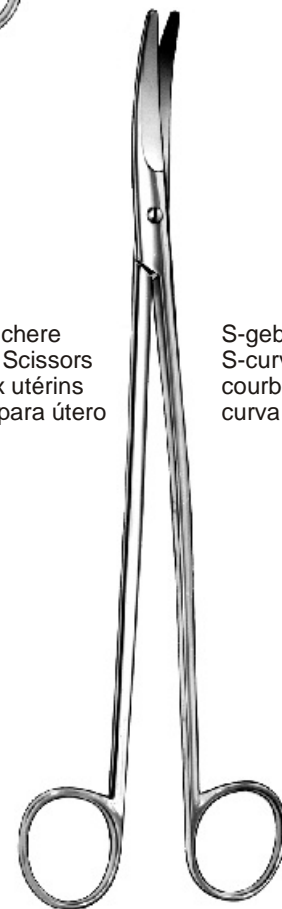

Siebold
 20-1907 24,0 cm/9½"

Uterusschere
 Uterine Scissors
 Ciseaux utérins
 Tijeras para útero

S-gebogen
 S-curved
 courbes forme S
 curva forma S

20

Scheren für Geburtshilfe
 Scissors for obstetrics
 Ciseaux à obstétrique
 Tijeras para obstetricia



Kephalotomie-Scheren
 Cephalotomy Scissors
 Ciseaux à céphalotomie
 Tijeras para cefalotomia

20-1908

Dubois
 27 cm/10½"



20-1909



20-1910
 14,5 cm/5½"

**Braun-
 Stadler**

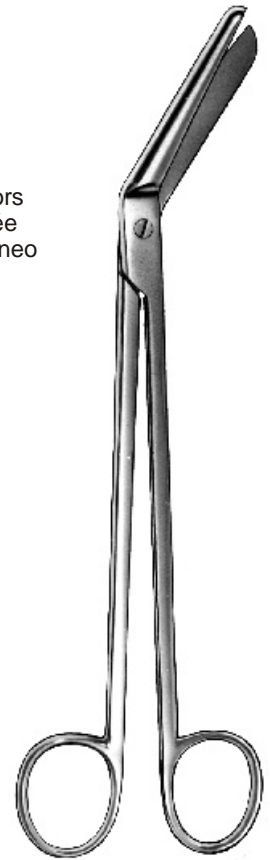

20-1911
 22 cm/8¾"

Dammscheren
 Perineum Scissors
 Ciseaux à périnée
 Tijeras para perineo



Dammschere
 Perineum Scissors
 Ciseaux à périnée
 Tijeras para perineo

Waldmann
 18,0 cm/7¼"

20-1910-18

Scheren für Geburtshilfe
Scissors for obstetrics
Ciseaux à obstétrique
Tijeras para obstetricia



Nabelschnurscheren
 Umbilical Scissors
 Ciseaux pour le cordon ombilical
 Tijeras umbilicales

Schumacher
 15,5 cm/6¼"

20-1912



Nabelschnurscheren
 Umbilical Scissors
 Ciseaux pour le cordon ombilical
 Tijeras umbilicales

Busch

20-1913 13,0 cm/5"
 20-1914 16,0 cm/6¼"



Mod. USA
 10,5 cm/4¼"

20-1915

20



Feine Chirurgische Scheren
 Delicate Operating Scissors
 Ciseaux chirurgicaux fins
 Tijeras finas para cirugía

20-1916

Joseph
 14,5 cm/5½"



20-1917



Präparierscheren
 Dissecting Scissors
 Ciseaux à dissection
 Tijeras para preparaciones

Kilner

20-1918 13,0 cm/5"
 20-1919 15,0 cm/6"

Gefäßscheren
Vascular Scissors
Ciseaux vasculaires
Tijeras vasculares

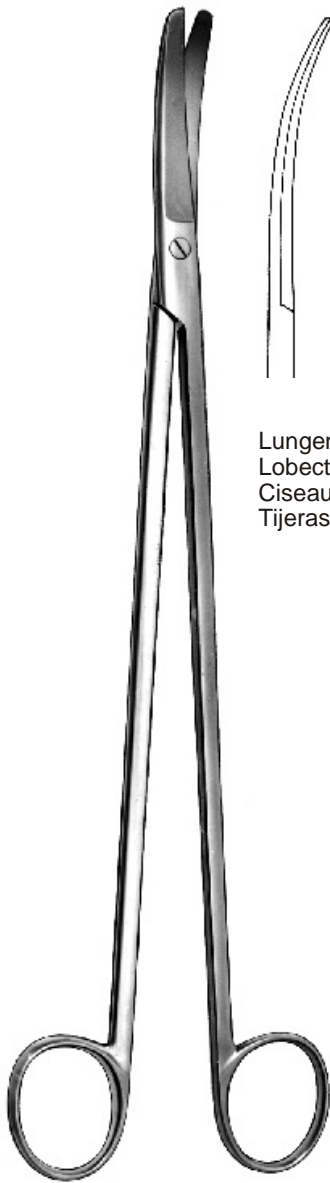

Lungenlappenschere
 Lobectomy Scissors
 Ciseaux à lobectomie
 Tijeras para lobectomia

Crafoord
 30,0 cm/12"
 20-1920

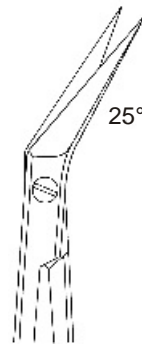

25°

20-1922-01

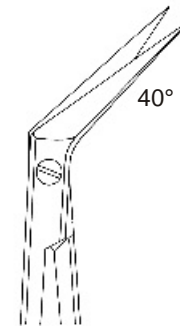

40°

20-1922-02

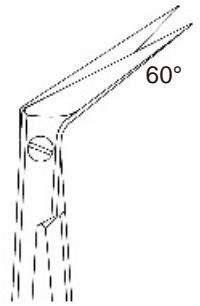

60°

20-1922-03

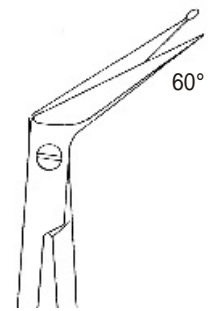

60°

20-1922-04

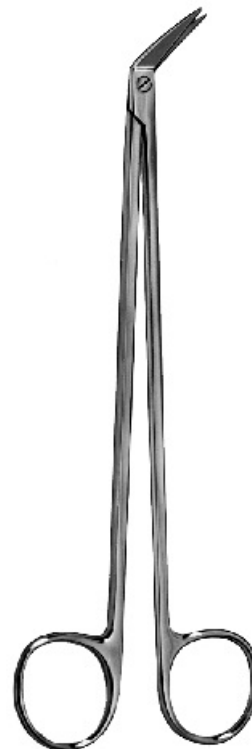

Potts-Smith
 19,0 cm/7½"

Gefäßscheren
Vascular Scissors
Ciseaux vasculaires
Tijeras vasculares

Präparierscheren
Dissecting Scissors
Ciseaux à dissection
Tijeras para preparaciones



Gefäßschere
 Vascular Scissors
 Ciseaux vasculaires
 Tijeras vasculares

Potts-Smith

20-1923 19,0 cm/7½"



Präparierschere
 Dissecting Scissors
 Ciseaux à dissection
 Tijeras para preparaciones

Reynolds

20-1924 16,0 cm/6¼"



Gefäßschere
 Vascular Scissors
 Ciseaux vasculaires
 Tijeras vasculares

Satinsky

20-1925 24,5 cm/10"



Knorpelschere
 Cartilage Scissors
 Ciseaux pour le cartilage
 Tijeras para cartilago

Mc Indoe

20-1926 19,0 cm/7½"

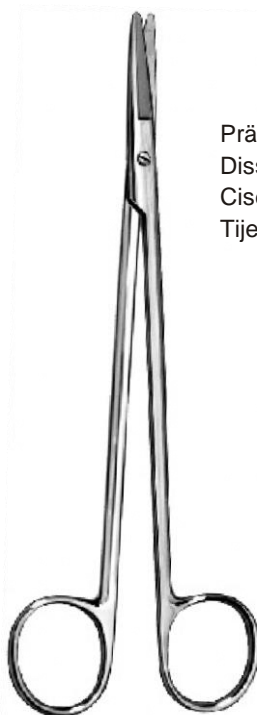

20-1927

Präparierscheren
 Dissecting Scissors
 Ciseaux à dissection
 Tijeras para preparaciones



Tönnis
 18,0 cm/7"

20-1928

20

